



1



XUD 11

XM
100-00/10

1

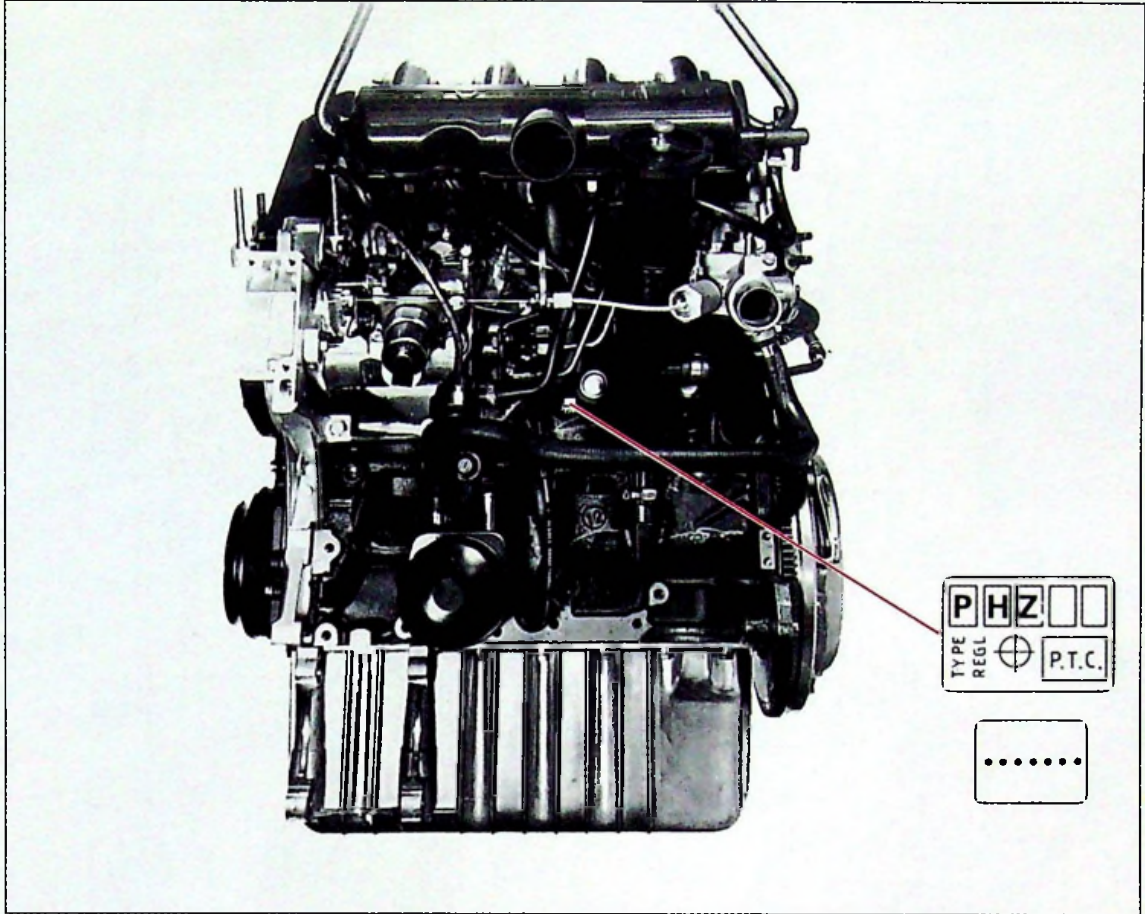

89-1237

4 CYL.

PHZ



4,3 mdaN

2,7 mdaN

1 mdaN

2,7 mdaN



E6

Y. 10-14

1°  7 mdaN

2°  60°

1,4 mdaN

4,5 mdaN



1,6 mdaN

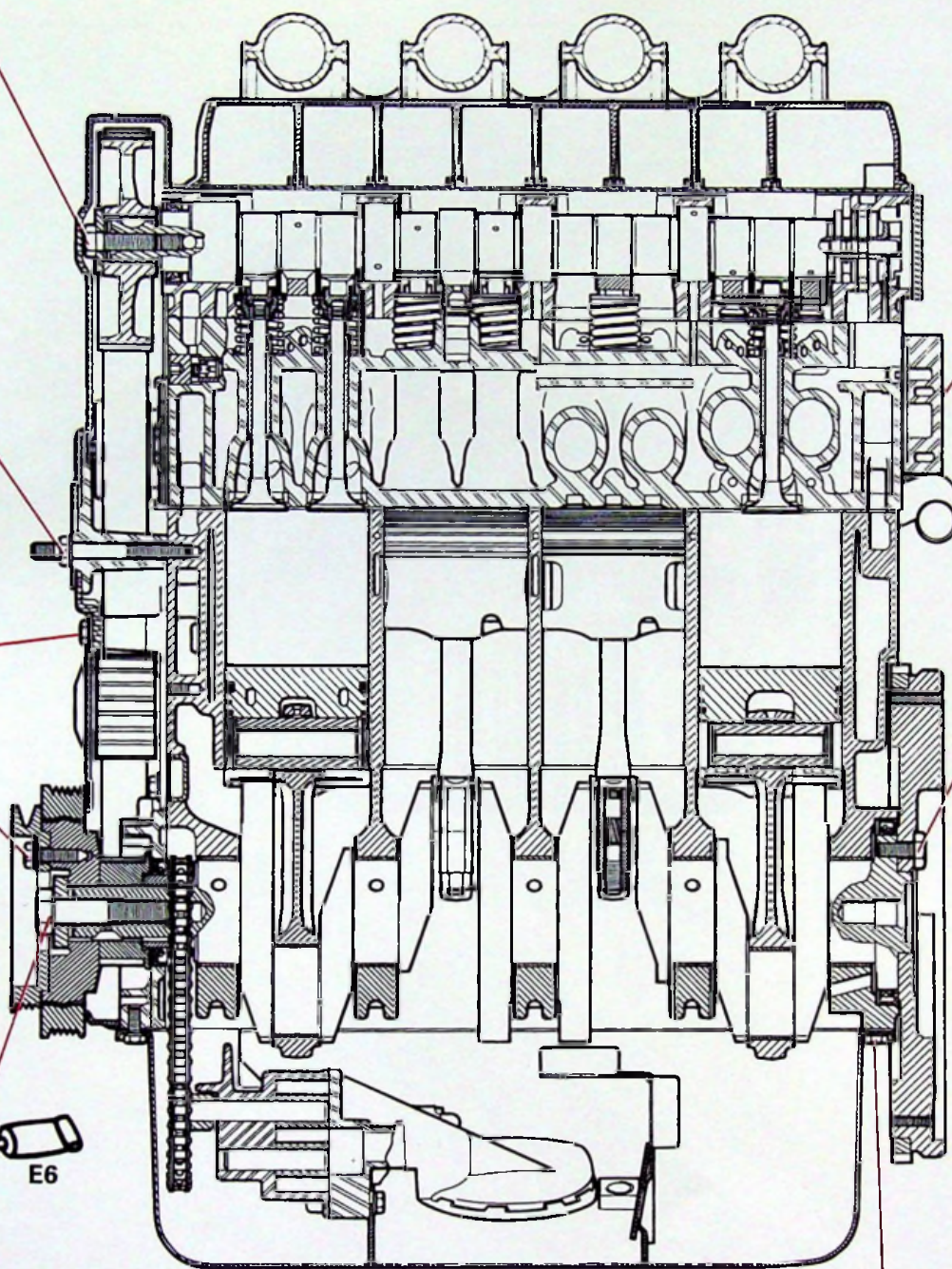



1



4 CYL.



PHZ

XM
100-00/10

3

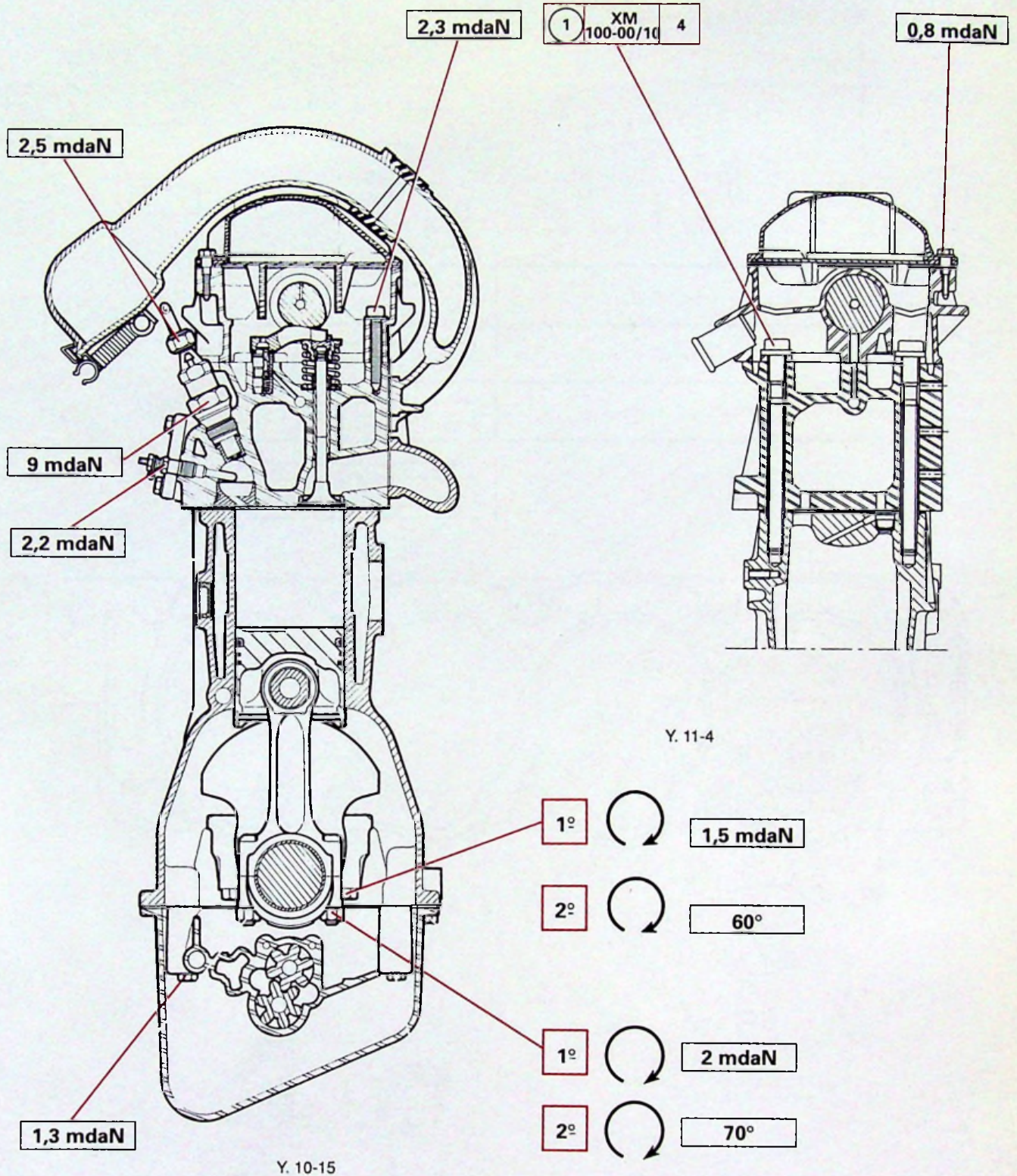

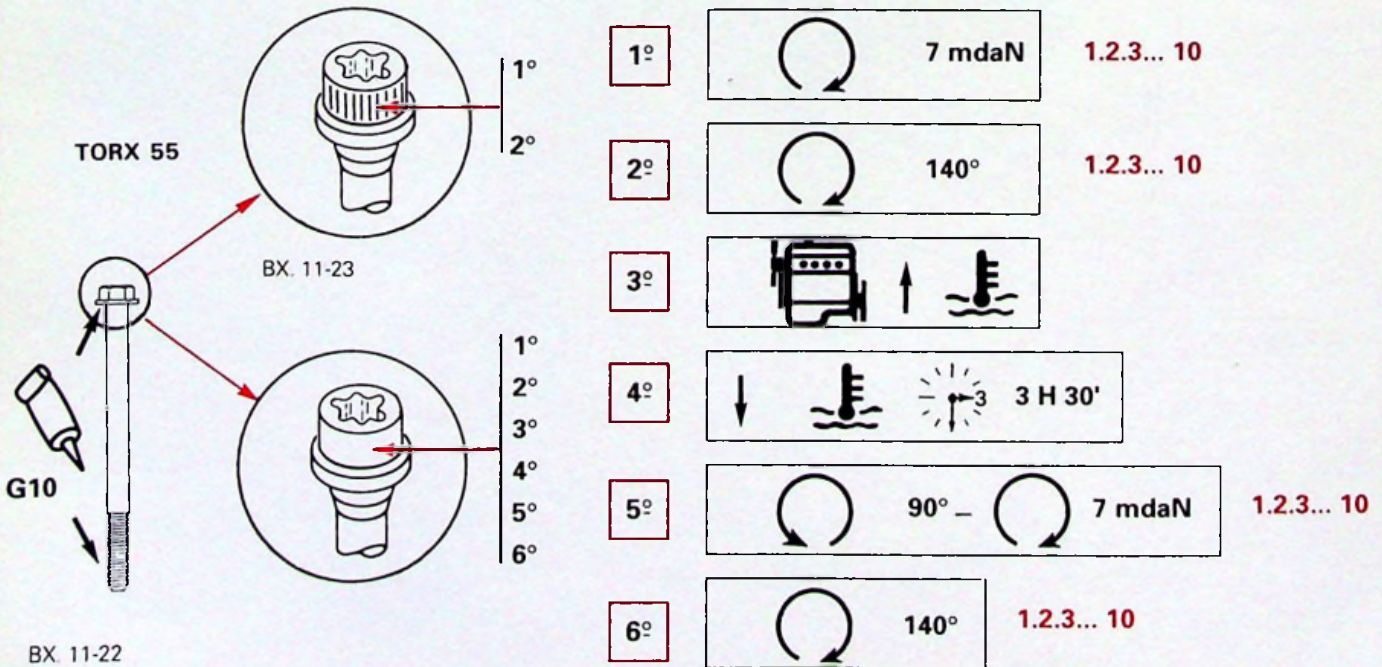
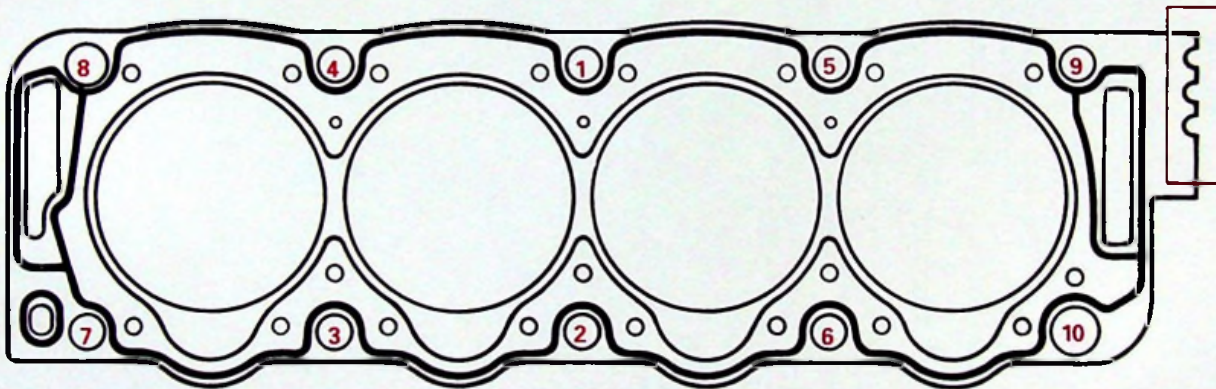
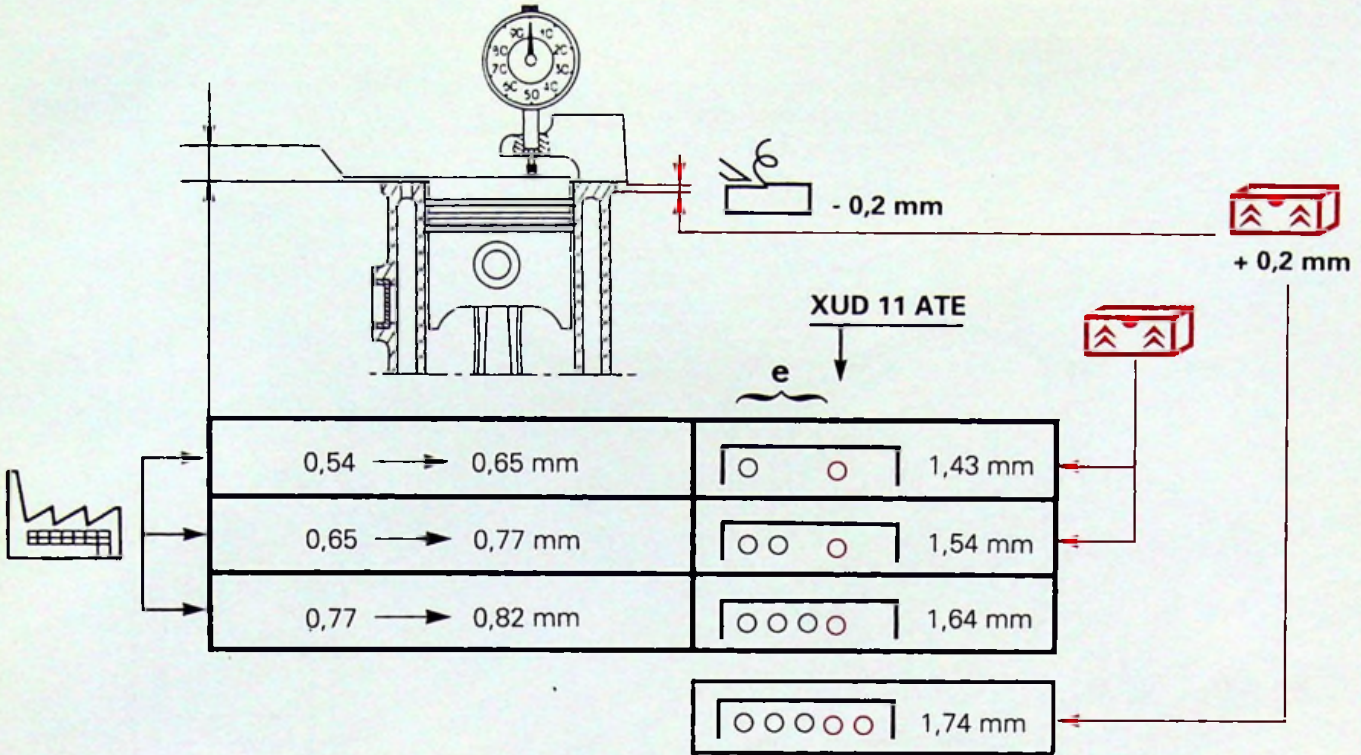



1



4 CYL.



PHZ

XM
100-00/10

5



PHZ

= XUD11ATE/Y



2088 cm³



× 4



× 12

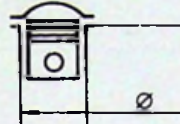

∅ = 85 mm

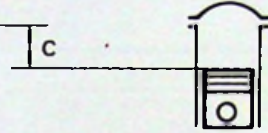

c = 92 mm

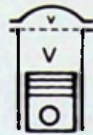

:

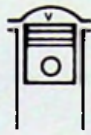

20,5 / 1



GAZOLE



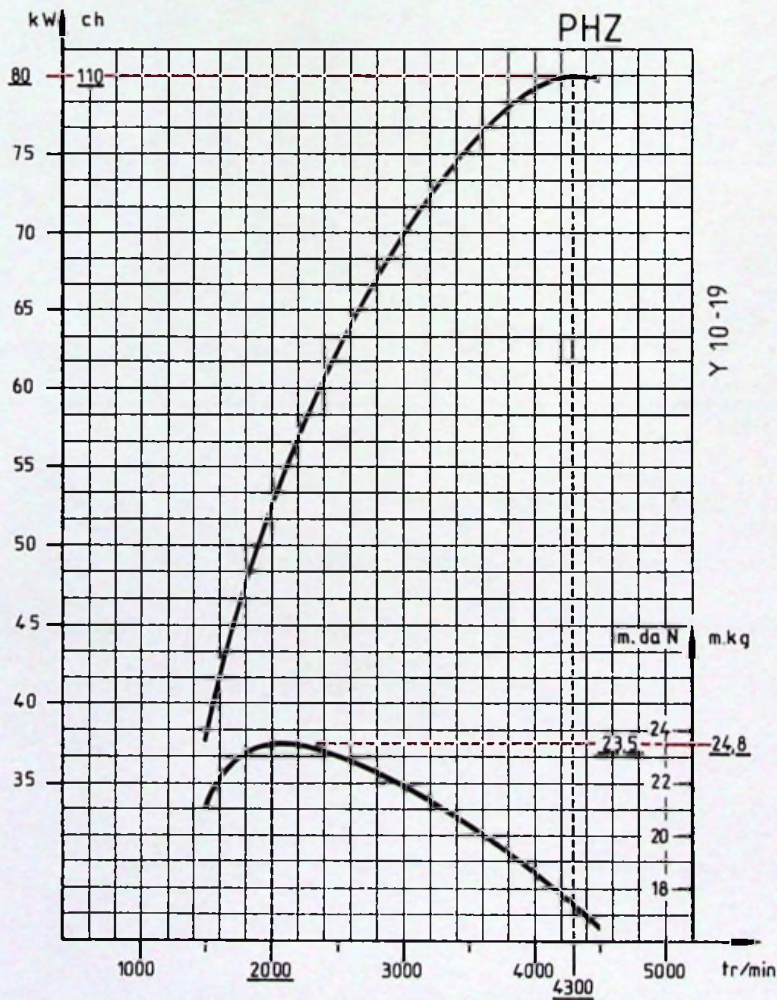

1. 3. 4. 2

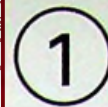

Y. 10-19

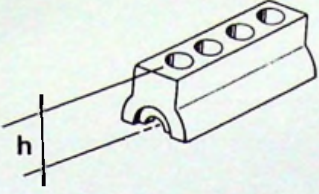
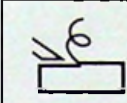
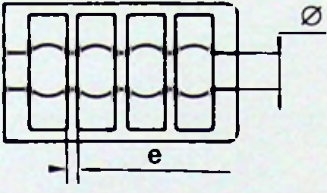
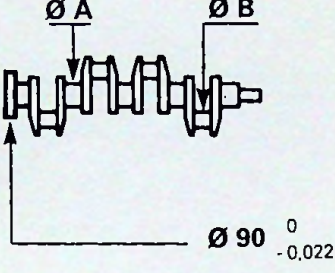
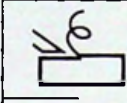
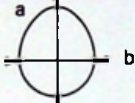
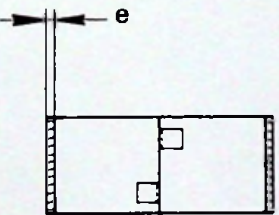

	$h = 235 \pm 0,05 \text{ mm}$	
	$h - 0,2 \text{ mm}$ $h = 234,80 \text{ Mini}$	
	$\varnothing = 63,750 \begin{matrix} 0 \\ - 0,019 \end{matrix} \text{ mm}$ $e = 21,82 \pm 0,05 \text{ mm}$	
  $- 0,2$  $a - b$  	A	B
	$60 \begin{matrix} 0 \\ - 0,019 \end{matrix} \text{ mm}$	$50 \begin{matrix} 0 \\ - 0,016 \end{matrix} \text{ mm}$
	$59,7 \begin{matrix} 0 \\ - 0,019 \end{matrix} \text{ mm}$	 $49,7 \begin{matrix} 0 \\ - 0,016 \end{matrix} \text{ mm}$
	$0,007 \text{ mm}$	$0,007 \text{ mm}$
	$1,842 \text{ mm}$	$1,827 \text{ mm}$ J
$1,992 \text{ mm}$ B	$1,977 \text{ mm}$ B	

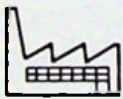

- (D)** Nach dem schleifen unbedingt neu nitrieren
- (DK)** Efter afdrejning/bearbejdning skalder foretages hændning af emnet ved illeld af nitrening
- (E)** Hacer imperativamente una nitruraciòn iònica después de la rectificaciòn
- (GB)** It is imperative to carry out an ionic nitriding after repair resurfacing
- (I)** Eseguire obbligatoriamente una nitrurazione ionica dopo la rettifica
- (NL)** Het is noodzakelijk na opzuivering te nitreeren
- (P)** Fazer impérativamente uma nitruração iónica após rectificação
- (S)** Efter bearbetning är det absolut nödvändigt att härda materialet med hjäld av nitrening
- (SF)** Kappale on ehdottomasti typtetskarkaistava käsittelyn jäl.Keen
- (F)** Faire impérativement une nitruration ionique après rectification



1





4 CYL.



PHZ

XM
100-00/10

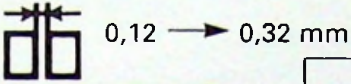
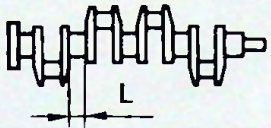
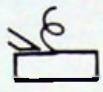
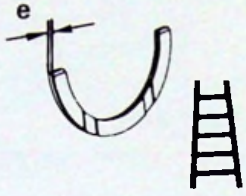
7

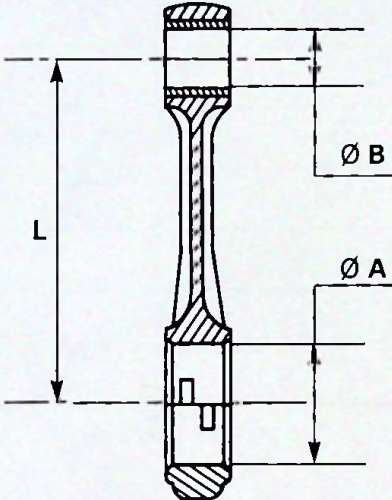
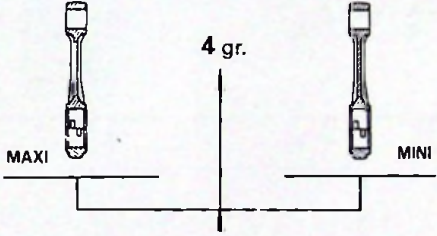
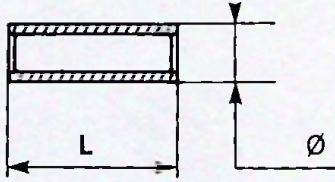
 		<p>$25,70^{+0,05}_0$ mm</p> <p>1 25,90 mm</p> <p>2 26,00 mm</p> <p>3 26,10 mm</p>
		<p>1,85 mm</p> <p>1 1,95 mm</p> <p>2 2,00 mm</p> <p>3 2,05 mm</p>
	<p>$\text{Ø A} = 53,695^{+0,013}_0$ mm</p> <p>$\text{Ø B} = 30,00^{+0,020}_{+0,007}$ mm</p> <p>L = 145 mm</p> 	
	<p>L = $71,5^0_{-0,3}$ mm</p> <p>Ø = $30^0_{-0,006}$ mm</p>	



	Ø A		$85^{+0,018}_0$ mm	
	A1		$85,030^{+0,018}_0$ mm	
		R1		$85,250^{+0,018}_0$ mm
		R2		$85,600^{+0,018}_0$ mm
	Ø B		$84,920 \pm 0,009$ mm	
	A1		$84,950 \pm 0,009$ mm	
		R1		$85,170 \pm 0,009$ mm
		R2		$85,520 \pm 0,009$ mm

	3 mm				
	R1	V		0,30	
	R2	V V		0,50	
	2 mm		V		
	R1	V BI		0,30	
	R2	V BI BI		0,50	
	3 mm		V		
	R1	V B		0,25	
	R2	V B B		0,50	

	A1 R1 R2	
		P1 - P2 - P3 - P4

--



1



4 CYL.



PHZ

XM
100-00/10

9

	x 12	3,5 mm	3,5 mm		
		13 ^{+0,059} _{+0,048} mm	13 ^{+0,059} _{+0,048} mm		
	1	13,290 ⁰ _{-0,011} mm	13,290 ⁰ _{-0,011} mm		
	2	13,590 ⁰ _{-0,011} mm	13,590 ⁰ _{-0,011} mm		
	1	35 ^{+0,137} _{+0,112} mm	35 ^{+0,137} _{+0,112} mm		
	2	35,30 ^{+0,137} _{+0,112} mm	35,30 ^{+0,137} _{+0,112} mm		
	Ø 1	33,9 mm	33,9 mm		
	Ø 2	8,005 ⁰ _{-0,015} mm	7,975 ⁰ _{-0,015} mm		
	L	122,3 mm	121,9 mm		
		8,40 mm	9,25 mm		
		4,84 mm	5,28 mm		

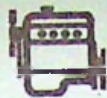

	Ø 1		12,981 $\begin{smallmatrix} +0,032 \\ 0 \end{smallmatrix}$ mm	12,981 $\begin{smallmatrix} +0,032 \\ 0 \end{smallmatrix}$ mm		
		1	13,211 $\begin{smallmatrix} +0,032 \\ 0 \end{smallmatrix}$ mm	13,211 $\begin{smallmatrix} +0,032 \\ 0 \end{smallmatrix}$ mm		
		2	13,511 $\begin{smallmatrix} +0,032 \\ 0 \end{smallmatrix}$ mm	13,511 $\begin{smallmatrix} +0,032 \\ 0 \end{smallmatrix}$ mm		
	Ø 2		35 ± 0,025 mm		35 ± 0,025 mm	
		1	35,30 ± 0,025 mm		35,30 ± 0,025 mm	
		2	35,50 ± 0,025 mm		35,50 ± 0,025 mm	
	8,15 ± 0,15 mm		8,55 ± 0,15 mm			
		1	8,35 ± 0,15 mm		8,75 ± 0,15 mm	
		2	8,35 ± 0,15 mm		8,75 ± 0,15 mm	
	Ø = 8,02 $\begin{smallmatrix} +0,022 \\ 0 \end{smallmatrix}$ mm		Ø = 8,02 $\begin{smallmatrix} +0,022 \\ 0 \end{smallmatrix}$ mm			
L = 41 ± 0,5 mm		L = 41 ± 0,5 mm				



1



4 CYL.



PHZ

XM
100-00/10

11

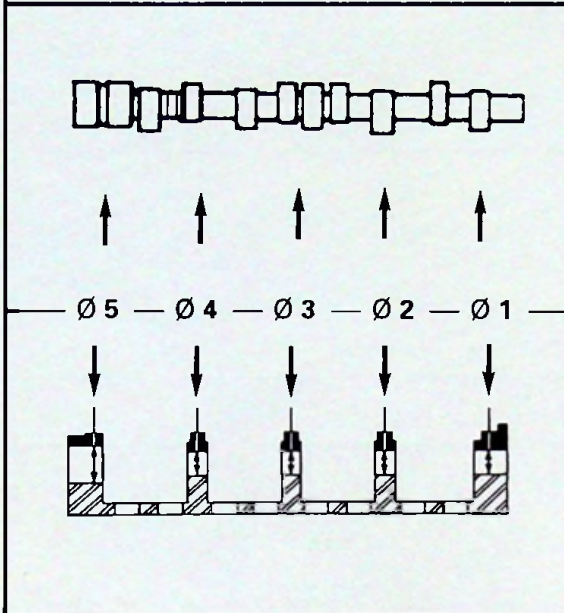
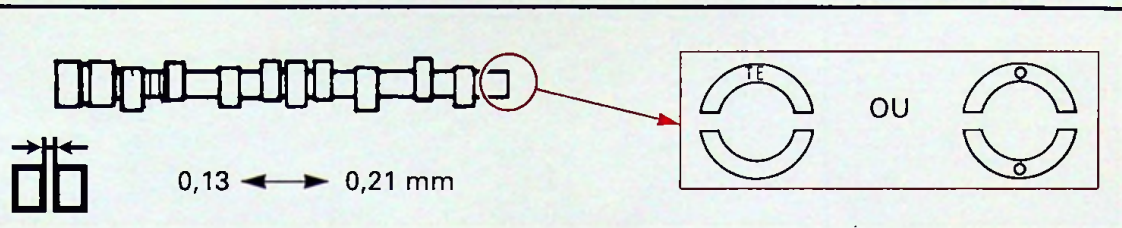

Ø 1	42,55	- 0,025 - 0,050	mm
Ø 2	43,7	- 0,025 - 0,050	mm
Ø 3	44,85	- 0,025 - 0,050	mm
Ø 4	46	- 0,025 - 0,050	mm
Ø 5	47,15	- 0,025 - 0,050	mm
Ø 1	42,565	+ 0,025 0	mm
Ø 2	43,715	+ 0,025 0	mm
Ø 3	44,865	+ 0,025 0	mm
Ø 4	46,015	+ 0,025 0	mm
Ø 5	47,165	+ 0,025 0	mm

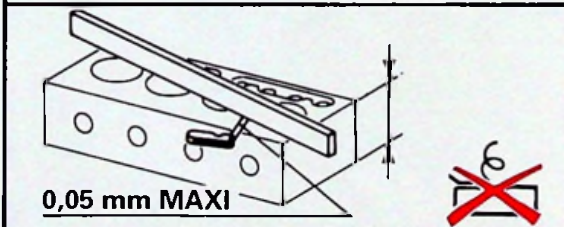

$h = 110 \pm 0,05$ mm

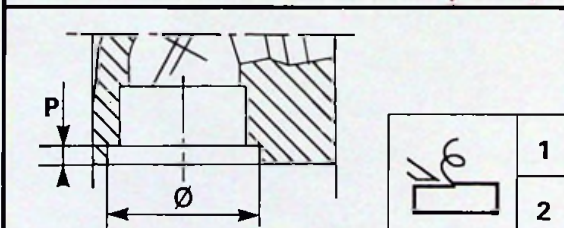

	Ø	P
	34	+ 0,039 0 mm
1	34,4	+ 0,039 0 mm
2	34,6	+ 0,039 0 mm

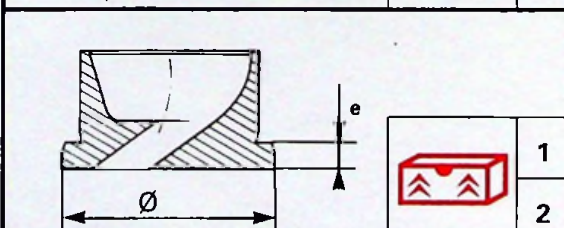

	Ø	e
	34,25	+ 0,039 0 mm
1	34,45	+ 0,039 0 mm
2	34,65	+ 0,039 0 mm

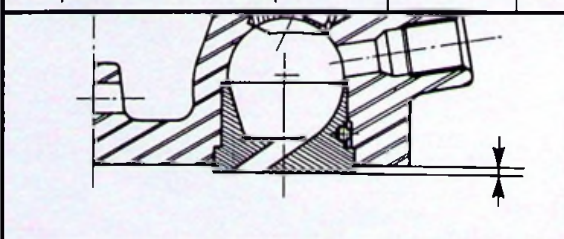

0 \longleftrightarrow 0,03 mm MAXI

$\sqrt{\text{0,015}}$

