





**TRANSMISSION**

EDITION 01/04/2002 - CAT. 14 740

**CITROËN**

**VOCABULAIRE**  
**GLOSSARY - VOCABULARIO - VOCABULÁRIO**  
**FACHBEGRIFFE - GLOSSARIO - WOORDENLÿST**

(F)	(GB)	(E)	(P)	(D)	(I)	(NL)
<b>G (gauche)</b>	Left	Izquierda	Esquerda	Links	Sinistro	Links
<b>D (droite)</b>	Right	Derecha	Direita	Rechts	Destro	Rechts
<b>Repère</b>	Identification mark	Marca	Marca	Bauteilmarkierung	Riferimento	Merkteken
<b>Neuve</b>	New	Nueva	Nova	Neu	Nuova	Nieuw
<b>E.S. Exchange standard</b>	Standard Exchange	Cambio estandard	Peça renovada	Austausch	Revisionato	Fabrieksruil
 <b>ABR</b>	With ABS (Anti lock brakes)	Con Anti-bloqueo rueda	Com Anti blocagem de roda	Mit Anti-Blockien System	Con Anti-bloccaggio ruota	Met Anti-blokkeer systeem
 <b>Sans ABR</b>	Without ABS (Anti lock brakes)	Senza Anti-bloqueo rueda	Sem Anti blocagem de roda	Ohne Anti-Blockien System	Sin Anti-bloccaggio ruota	Zonder Anti-blokkeer systeem
<b>Coté Roue</b>	Wheel side	Lato ruota	Lado roda	Radseitig	Lado rueda	Kant wiel
<b>Coté BV</b>	Gear box side	Lato scatola del cambio	Lado caixa de velocidades	Getriebegehauseitig	Lado Cajade velocidades	Kant versnellingsbak
<b>TT</b>	All types	Todos los tipos	Todos os tipos	Alle typen	tutti i tipi	Alle typen
<b>(BL) Berline</b>	Saloon	Berlina	Berline	Limousine	Berlina	Berline
<b>(BK) Break</b>	Estate	Break	Break	Kombi	Break	Break

5 bonnes raisons de préférer les organes Echange-Standard CITROËN.

**F**

- 1 - **QUALITE** - Un souci permanent de rigueur : dans la fabrication, le reconditionnement, les contrôles. - **FIABILITE.**
  - 2 - **NORMES** - Une pièce CITROËN : la perspective d'un montage rapide, sans difficulté, sans surprise. - **FACILITE.**
  - 3 - **GAMME** - La référence qu'il vous faut, quand il vous la faut. - **DISPONIBILITE.**
  - 4 - **SERVICE** - Une garantie 12 mois Pièces et Main d'oeuvre : l'assurance supplémentaire du constructeur, pour plus de confiance - **SECURITE.**
  - 5 - **GAIN** - Un coût maîtrisé : un bon rapport qualité/prix. - **RENTABILITE.**
- 

Five good reasons to use CITROËN'S exchange engines :

**GB**

- 1 - **QUALITY** - Reconditioning is carried out under strict quality controls. - **RELIABILITY.**
  - 2 - **STANDARDS** - A CITROËN part : The prospect of easy fitting, without difficulty, without surprises. - **EASE OF FITMENT.**
  - 3 - **RANGE** - The part you need when you need it. - **AVAILABILITY.**
  - 4 - **SERVICE** - A 12 months labour & parts warranty : the additional assurance of the manufacturer for more confidence. **SECURITY.**
  - 5 - **BENEFIT** - A competitive price : Value for money. - **PROFITABILITY.**
- 

5 buenas razones para preferir los órganos "Cambio-Standard" CITROËN.

**E**

- 1 - **CALIDAD** - Una preocupación constante por el rigor : en la fabricación, el reacondicionado, los controles. - **FIABILIDAD.**
  - 2 - **NORMAS** - Una pieza CITROËN : la idea de un montaje rápido, sin dificultades, sin sorpresas. - **FACILIDAD.**
  - 3 - **GAMA** - La referencia que usted necesite, cuando la necesite. - **DISPONIBILIDAD.**
  - 4 - **SERVICIO** - Una garantía de 12 meses en piezas y mano de obra : el respaldo suplementario del constructor, para una mayor confianza. - **SECURIDAD.**
  - 5 - **GANANCIA** - Un coste óptimo : una buena relación calidad/precio. - **RENTABILIDAD**
- 

5 boas razões para preferir as Peças Renovadas CITROËN.

**P**

- 1 - **QUALIDADE** - Um cuidado permanente no rigor a fabricação, o acondicionamento, o controlo. - **FIABILIDADE.**
  - 2 - **NORMAS** - Uma peça CITROËN a perspectiva de uma montagem rápida, sem dificuldades, sem surpresas. - **FACILIDADE.**
  - 3 - **GAMA** - A referencia necessaria quando é necessário. - **DISPONIBILIDADE.**
  - 4 - **SERVIÇO** - Uma garantia de 12 meses Peças e Mão de obra : a segurança suplementar do construtor, para mais confiança. - **SEGURANÇA.**
  - 5 - **GANHO** - Um bom preço uma boa relação qualidade/preço - **RENTABILIDADE.**
- 

5 gute Gründe, CITROËN Austausch-Bauteile zu bevorzugen.

**D**

- 1 - **QUALITÄT** - Eine ständige strenge Qualität-süberwachung : während der Fabrikation, der Aufarbeitung, den Abschlusskontrollen. - **ZUVERLÄSSIGKEIT.**
  - 2 - **NORM** - Ein CITROËN Ersatzteil : die Gewähr auf eine schnelle Montage, ohne Schwierigkeiten, ohne Überraschungen- **EINFACHHEIT.**
  - 3 - **UMFANG** - Die benötigte Ersatzteilnummer dann, wann Sie sie brauchen. - **VERFÜGBARKEIT.**
  - 4 - **SERVICE** - 12 Monate Garantie auf Ersatzteil und Einbau : zusätzliche Sicherheit vom Hersteller für mehr Vertrauen. **SICHERHEIT.**
  - 5 - **VORTEIL** - Eingeschränkte Kosten : ein hervorr-agendes Qualitäts/Preis-Verhältnis - **WIRTSCHAFTLICHKEIT.**
- 

5 buone ragioni per preferire i Ricambi revisionati CITROËN.

**I**

- 1 - **QUALITA'** - Un pensiero permanente di rigore : nella costruzione, nella revisione nei controlli. - **AFFIDABILITA'.**
  - 2 - **NORME** - Un ricambio CITROËN : la prospettiva di un montaggio rapido, senza difficoltà, senza sorprese. - **FACILITA'.**
  - 3 - **GAMMA** - Il ricambio che Vi necessita, quando Vi necessita. - **DISPONIBILITA'.**
  - 4 - **SERVIZIO** - Una garanzia 12 mesi per Ricambi e Manodopera : l'assicurazione supple-mentare del costruttore, più affidabilità. **SICUREZZA.**
  - 5 - **GUADAGNO** - Un costo controllato : un buon rapporto qualità/Prezzo. - **REDDITIVITA'.**
- 

5 goede redenen om de voorkeur te geven aan CITROËN-ruildelen.

**NL**

- 1 - **KWALITEIT** - Constante kwaliteitszorg : kwaliteitscontroles tijdens fabricage en revisie. - **BETROUWBAARHEID.**
- 2 - **NORMEN** - Een CITROËN-onderdeel betekent een snelle en probleemloze montage. - **GEBRUIKSGEMAK.**
- 3 - **VOLLEDIG GAMMA** - Altijd het juiste onderdeel op het moment dat u het nodig heeft. - **BESCHIKBAARHEID.**
- 4 - **SERVICE** - 12 jaar garantie op onderdeel en montage : een extra zekerheid die CITROËN u kan bieden.
- 5 - **PRIJS** - Kostenbeheersing : goede prijs-kwaliteit verhouding. - **RENTABILITEIT.**

**CONDITIONS DE VENTE DES ORGANES NEUFS OU ECHANGE STANDARD, VENDUS AVEC LA REPRISE DE L'ORGANE USAGE.**

FRANCE :

Les organes neufs et Echange Standard CITROËN ne doivent être montés qu'en remplacement d'un organe usagé du même type et sur le ou les types de véhicule de notre Marque, indiqués à notre catalogue à l'exclusion de tout autre usage.

Nous déclinons toute responsabilité dans le cas où ils seraient utilisés à des usages différents.

Les organes usagés retournés en contrepartie ne devront pas avoir subi de détériorations extérieurement visibles - autres que l'usure normale - et de plus, ils devront être normalement assemblés et dans un état de propreté permettant leur examen technique.

Tout organe usagé doit être retourné dès dépose, selon les modalités prescrites par le département Pièces de Rechange.

**Nota** : Pour les pays non mentionnés ci-dessus, pour les conditions générales de vente locales, veuillez vous adresser auprès du département Pièces de Rechange de l'importateur CITROËN de votre pays.

**Important** : Les moteurs et les boîtes de vitesses retournés doivent être vidangés.

Avant de passer commande, nous vous conseillons vivement de consulter le microcatalogue du véhicule afin de connaître tous les renseignements techniques nouveaux ou complémentaires (par exemple : le ou les "D.E.O.").

F

**CONDITIONS OF SALE FOR NEW OR EXCHANGE UNITS WHEN THE RETURN OF THE OLD UNITS IS "REQUIRED".**

U.K. :

CITROËN new and exchange units must only be fitted as replacement for ones of the same type and on vehicle(s) indicated in our catalogue.

CITROËN will accept no responsibility if they are used for other means.

All returned units must be complete and fully assembled.

All units must be drained of oil, plugged to prevent leakage and thoroughly degreased.

All units must be returned in the original packaging and engines securely attached to the pallets provided.

All old units must be returned as soon as possible in accordance with the instructions listed in the Parts Operating Manual Section 6.3.

Before placing an order, we advise you to check the microcatalogue of the relevant vehicle to obtain all the latest technical information. (for example : D.E.O. -Order in Addition-).

GB

**CONDICIONES DE VENTA DE ÓRGANOS NUEVOS O CAMBIO STANDARD, VENDIDOS CON LA RECUPERACIÓN DEL ÓRGANO USADO.**

FRANCIA :

Los órganos nuevos y "Cambio-Standard CITROËN no deben ser montados nada más que en sustitución de un órgano usado del mismo tipo y sobre el o los tipos de vehículo de nuestra Marca, indicados en nuestro catálogo excluyendo cualquier otro uso.

Declinamos toda responsabilidad en el caso de que sean utilizados para usos diferentes.

Los órganos usados devueltos a cambio, no deberán haber sufrido deterioros exteriores visibles, salvo los propios del desgaste, y además deberán estar ensamblados y en un estado de limpieza adecuado para permitir su examen técnico.

Todo órgano usado deberá ser devuelto de acuerdo con las normas establecidas por el departamento de Piezas de Recambio.

**Nota** : Referente a las condiciones generales de venta, todos los países no relacionados anterior-mente, deberán dirigirse al departamento de Piezas de Recambio del importador CITROËN de su país.

**Importante** : Los motores y las cajas de cambio devueltos deberán estar vacíos.

Before placing an order, we advise you to check the microcatalogue of the relevant vehicle to obtain all the latest technical information. (for example : D.E.O. -Order in Addition-).

E

**CONDIÇÕES DE VENDA DOS ÓRGÃOS NOVOS OU RENOVADOS, VENDIDOS COM A RETOMA DO ÓRGÃO USADO.**

FRANÇA :

Os órgãos novos e Renovados CITROËN só devem ser montados em substituição dum órgão usado do mesmo tipo no tipo ou tipos de veículo da nossa Marca, indicados no nosso catálogo à exclusão de qualquer outro uso.

Recusamos toda a responsabilidade caso sejam utilizados para usos diferentes.

Os órgãos usados devolvidos em contrapartida não podem estar deteriorados exteriormente visíveis - além do desgaste normal - além disso - devem estar montados normalmente e limpos de forma a permitir um exame técnico

Todo o órgão usado deve ser devolvido após desmontagem, conforme às normas proscritas pelo departamento de Peças.

**Nota** : Para os países não mencionados a ulma, para as condições gerais de venda locais, queira dirigir se ao departamento de Peças do importador CITROËN do seu país.

**Importante** : Os motores e caixas de velocidades devolvidas devem estar despejadas.

Antes de fazer a encomenda, aconselhamos vivamente a consultar a microficha do veículo afim de conhecer todas as informações técnicas novas o complementares (por exemplo o ou os "D.E.O.")

P

**VERKAUFSBEDINGUNGEN FÜR NEU- UND AUSTAUSCHTEILE, MIT ALTTEILRÜCKGABE.**

FRANKREICH :

Die Neu- und Austauschteile dürfen nur als Ersatz für ein Bauteil des gleichen Typs und in Fahrzeuge unserer Marke, so wie in unserem Katalog zugeordnet unter Ausschluss jeder anderweitigen Verwendung montiert werden.

Wir lehnen jegliche Verantwortlichkeit im Fall einer abweichenden Montage ab.

Die benutzten Bauteile, die als Gegenstück zurückgeschickt werden, dürfen keine sichtbaren äusseren Beschädigungen - abgesehen von normalem Verschleiss - aufweisen und müssen ausserdem im Normalzustand zusammengebaut und in sauberem Zustand, der eine technische Prüfung ermöglicht, sein.

Alle Altteile müssen in der vorgegebenen Zeit, nach den von der Ersatzteil-Abteilung vorgeschriebenen Modalitäten zurückgeschickt werden.

**Anmerkung** : Für alle nicht oben erwähnten Länder wenden Sie sich bezüglich der lokalen generellen Abwicklung an die Ersatzteil-Abteilung des CITROËN Importateurs Ihres Landes.

**Wichtig** : Die zurückgeschickten Motoren und Getriebe müssen von Betriebsflüssigkeiten (Öl) entleert sein.

Bevor Sie Ihre Bestellung aufgeben, sollten Sie unbedingt im Microfilm des Fahrzeugs nachsehen, um sich über alle neuen technischen Hinweise oder Zusatz (zum Beispiel : d.e.o - Teile) zu informieren.

D

**CONDIZIONI DI VENDITA TRASMISSIONI NUOVE O REVISIONATE CON RIPRESA DELL'USATO.**

FRANCIA :

Le Trasmissioni Nuove e Revisionate CITROËN devono essere montate solo in sostituzione di una trasmissione avariata dello stesso tipo su veicoli della ns. marca, escludendo ogni altro utilizzo.

Decliniamo ogni responsabilità in cui fossero utilizzati per scopi differenti.

La vendita delle Trasmissioni Nuove e Revisionate rientra nel sistema detto "Contropartita", pertanto la loro fornitura è effettuata alle condizioni normative previste da tale sistema.

Inoltre, le trasmissioni usate rese in contropartita devono corrispondere ai seguenti requisiti :

- Non dovranno aver subito danni esterni visibili,

- Dovranno essere montate e complete nelle loro parti,

- Dovranno essere imballate singolarmente nell'imballo originale e riportare il numero di codice sull'imballo stesso.

Prima di passare l'ordine, vi consigliamo vivamente di consultare il microcatalogo del veicolo al fine di conoscere tutti i riferimenti tecnico nuovi o complementari (per es. : il o i "D.E.O.").

I

**NIEUWE ONDERDELEN OF RUILDELEN MET TERUGNAME VAN HET GEBRUIKTE ONDERDEEL.**

VOOR NEDERLAND :

Het defecte (ruil-)onderdeel dient samen met de cautiebon te worden geretourneerd, anders kan er geen creditering plaatsvinden.

Het retourzenden dient te geschieden binnen 12 maanden na de datum van levering van het overeenkomende nieuwe of gerevideerde onderdeel.

Overige voorwaarden voor creditering zijn :

- Het defecte deel dient compleet, niet beschadigd en gereinigd te zijn. Van motoren en versnellingsbakken de olie afgetapt I







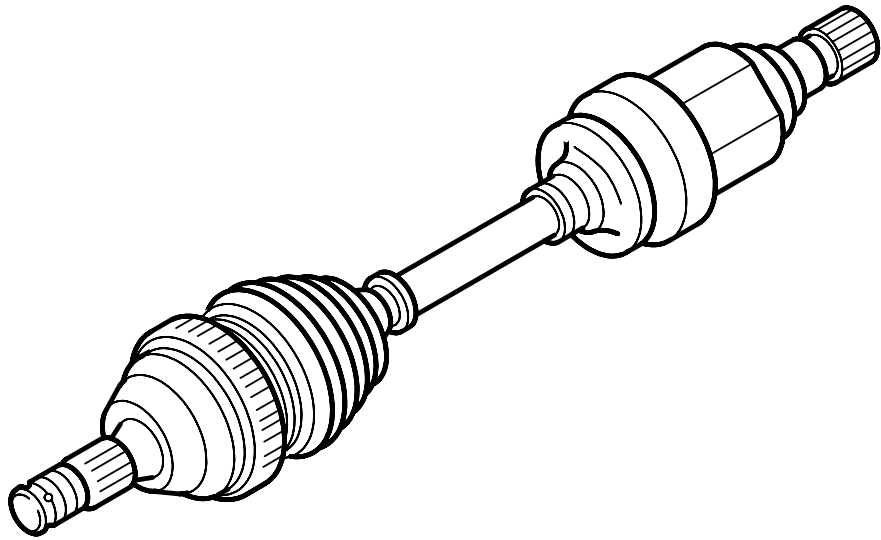



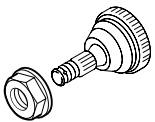
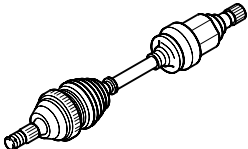

- Retourzendingen franco met onze reguliere transporteur. De retourvracht is voor uw rekening als u via een andere expediteur retourneert.

Voordat u een onderdeel bestelt, raden wij u ten eerste aan de microfiche te raadplegen voor alle nieuwe of extra technische informatie (b.v. de "D.E.O.").









NL

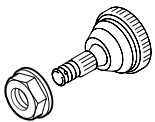
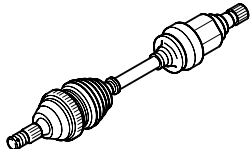

# CITROËN AX

<b>BV - MA</b>				G	D	Repère	Neuve	E.S.
		G	D	Repère	Neuve	E.S.		
(TU9-TU1) Ess 1 L - 1,1 L	 <b>3297 24</b>  Ø 20 x 150 - H 28,5	G	D	GE 76 GI 69	3272 50	3272 8J		
		D			3273 C8	3273 5J		
(TU3) Sauf <b>TU3FJ</b> Ess 1,4 L → 04/91 (TU2.4) <b>Sport</b> (TUD3) DI 1,4 L → 04/91	 <b>3297 24</b>  Ø 20 x 150 - H 28,5	G	D	GE 76 GI 69	3272 50	95 624 994		
		D			3273 C8	95 624 995		
(TU3) Sauf <b>TU3FJ</b> Ess 1,4 L 04/91 → <b>4x4</b> (Transmission AV) (TUD3-TUD5) DI 1,4 L 04/91 → DI 1,5 L	 <b>3297 14</b>  Ø 20 x 150 - H 18	G	D	GE 76 GI 69	3272 V2	3272 9J 		
		D			3273 08	3272 1K 		
		G			3273 5K 	3273 5L 		
		D			3273 08	3273 5L 		
(TU3FJ) Ess 1,4 L IE Multipoint 	 <b>3297 14</b>  Ø 20 x 150 - H 18	G	D	GE 76 GI 69	3272 R9	3272 6J		
		D			3273 Y4	3273 5G		
(TU3FJ) Ess 1,4 L IE Multipoint 	 <b>3297 14</b>  Ø 20 x 150 - H 18	G	D	GE 76 GI 69	3272 T9	3272 7J		
		D			3273 05	3273 5H		

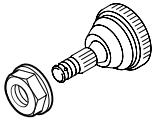
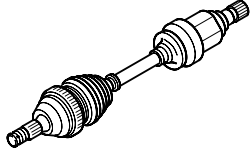









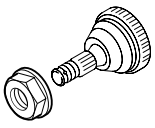
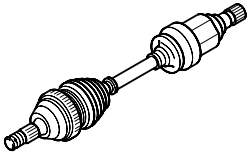







# CITROËN AX

<b>CITROËN AX</b>						
<b>BV - MA</b>						
		G	D	Repère	Neuve	E.S.
(TU3J2) Ess 1,4 L IE Multipoint		 <b>3297 14</b>	<b>G</b>		<b>3272 X6</b>	-
		Ø 20 x 150 - H 18	<b>D</b>		<b>3273 T1</b>	-
(TU3J2) Ess 1,4 L IE Multipoint		 <b>3297 14</b>	<b>G</b>		<b>3272 X7</b>	-
		Ø 20 x 150 - H 18	<b>D</b>		<b>3273 T2</b>	-
4x4 (Transmission AR)		 <b>3297 24</b>	<b>G</b>		<b>96 060 506</b>	-
		Ø 20 x 150 - H 18	<b>D</b>		<b>96 060 507</b>	-
<b>BV - SA13</b>						
		G	D	Repère	Neuve	E.S.
		 <b>3297 24</b>	<b>G</b>		<b>3272 S0</b>	-
		Ø 20 x 150 - H 18	<b>D</b>		<b>3273 Y5</b>	-

Transmission AR : Rear driveshaft - Transmision trasera - Transmissão de trás - Hintere gelenkwelle - Trasmissione posteriore - Aandrijf-as achter

 Electrique : Elctric - Elctrico - Elctrico - Elektrisch - Elettrico - Electrisch

# CITROËN SAXO

<b>BV - MA</b>							
			G	D			
(TU9-TU1-TU1M+) Ess 1 L - 1,1 L → 08/99	 	 <b>3297 24</b> Ø 20 x 150 - H 28,5	G			<b>3272 W5</b>	<b>3272 3J</b>
			D			<b>3273 56</b>	<b>3273 5C</b>
(TU9M-TU1M+) Administration Ess 1 L - 1,1 L → 01/99 (TU3.2-TU3JP) Ess 1,4 L → 01/99 (TUD5) DI 1,5 L → 01/99	   	 <b>3297 14</b> Ø 20 x 150 - H 18	G			<b>3272 W8</b>	<b>3272 4J</b>
			D			<b>3273 63</b>	<b>3273 5E</b>
(TU9M-TU1JP) Ess 1 L - 1,1 L 01/99 → (TU3JP) Ess 1,4 L 01/99 → (TUD5) DI 1,5 L 01/99 →	  	 <b>3297 24</b> Ø 20 x 150 - H 28,5	G			<b>3272 9P</b>	<b>3272 1Q</b>
			D			<b>3273 7F</b>	<b>3273 7G</b>
(TU1M+) Ess 1,1 L 01/99 →		 <b>3297 24</b> Ø 20 x 150 - H 28,5	G		<b>3272 9P</b>	<b>3272 1Q</b> → 09/2000	
						<b>3272 9S</b> 09/2000 → Direction non assistée	
						<b>3272 1Q</b> 09/2000 → Direction assistée	
			D		<b>3273 7F</b>	<b>3273 7G</b> → 09/2000	
	<b>3273 8A</b> 09/2000 → Direction non assistée						
	<b>3273 7G</b> 09/2000 → Direction assistée						
(TU1-TU1M-TU3.2-TU3JP) Ess 1,1 L - 1,4 L → 01/99 (TUD5) DI 1,5 L → 01/99		 <b>3297 14</b> Ø 20 x 150 - H 18	G			<b>3272 V2</b>	<b>3272 5J</b>
			D			<b>3273 08</b>	<b>3273 5F</b>
(TU1-TU1JP-TU1M-TU3JP) Ess 1,1 L - 1,4 L 01/99 → (TUD5) DI 1,5 L 01/99 →		 <b>3297 24</b> Ø 20 x 150 - H 28,5	G			<b>3272 2Q</b>	<b>3272 3Q</b>
			D			<b>3273 7H</b>	<b>3273 7J</b>

Administration : Fleet - Administracion - Administração - Dehorde - Flottes - Wagenpark Franse overheid (niet voor benelux)

Direction non assistée : Without power steering - Direccion no assistida - Direcção não assistida - Mechanische lenkung - Senza servosterzo - Zonder stuurbekrachtiging











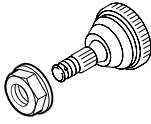
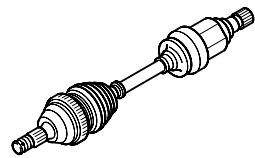



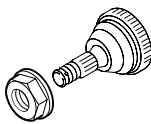
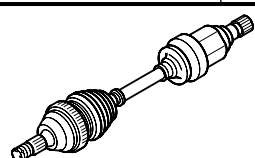

Direction assistée : Power steering since - Direccion assistida - Direcção assistida - Servo-lenkung - Servosterzo - Stuurbekrachtiging

 Roue fixation 3 trous : Wheel with 3 bolt fixings - Disco de rueda con 3 taladros fijacion - Roda 3 parafusos - 3 loch felge - Ruota fissaggio 3 fori - Wiel bevestiging 3 gaten

 Roue fixation 4 trous : Wheel with 4 bolt fixings - Disco de rueda con 4 taladros fijacion - Roda 4 parafusos - 4 loch felge - Ruota fissaggio 4 fori - Wiel bevestiging 4 gaten

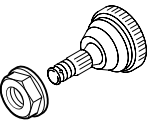
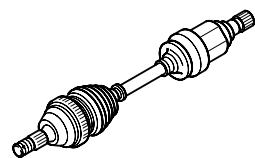







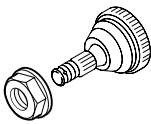
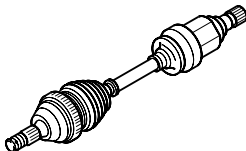

# CITROËN SAXO

<b>BV - MA</b>							
			G	D	Repère	Neuve	E.S.
(TU5JP-TU5J4) Ess 1,6 L - 1,6 L 16S → 01/99		 <b>3297 14</b> Ø 20 x 150 - H 18	G			<b>3272 R9</b>	<b>3272 6J</b>
			D			<b>3273 Y4</b>	<b>3273 5G</b>
(TU5JP-TU5J4) Ess 1,6 L - 1,6 L 16S 01/99 →		 <b>3297 24</b> Ø 20 x 150 - H 28,5	G			<b>3272 4Q</b>	<b>3272 5Q</b>
			D			<b>3273 7K</b>	<b>3273 7L</b>
(TU5JP-TU5J4) Ess 1,6 L - 1,6 L 16S → 01/99		 <b>3297 14</b> Ø 20 x 150 - H 18	G			<b>3272 T9</b>	<b>3272 7J</b>
			D			<b>3273 05</b>	<b>3273 5H</b>
(TU5JP-TU5J4) Ess 1,6 L - 1,6 L 16S 01/99 →		 <b>3297 24</b> Ø 20 x 150 - H 28,5	G			<b>3272 8Q</b>	<b>3272 9Q</b>
			D			<b>3273 7Q</b>	<b>3273 7R</b>
<b>BVA - MB3</b>							
			G	D	Repère	Neuve	E.S.
(TU3JP-TU5JP) Ess 1,4 L - 1,6 L → 01/98		 <b>3297 14</b> Ø 20 x 150 - H 18	G			<b>3272 T7 *</b>	<b>3272 2K</b>
			D			<b>3273 03 *</b>	<b>3273 5N</b>
(TU3JP-TU5JP) Ess 1,4 L - 1,6 L 01/98 → 01/99		 <b>3297 14</b> Ø 20 x 150 - H 18	G			<b>3272 8C *</b>	<b>3272 2K</b>
			D			<b>3273 3P *</b>	<b>3273 5N</b>
(TU3JP-TU5JP) Ess 1,4 L - 1,6 L 01/99 →		 <b>3297 24</b> Ø 20 x 150 - H 28,5	G			<b>3272 6Q *</b>	<b>3272 1T</b>
			D			<b>3273 7N *</b>	<b>3273 8B</b>
<b>BV - SA13</b>							
			G	D	Repère	Neuve	E.S.
 → 01/99		 <b>3297 14</b> Ø 20 x 150 - H 18	G			<b>3272 X5</b>	—
			D			<b>3273 0G *</b>	—
 01/99 →		 <b>3297 24</b> Ø 20 x 150 - H 28,5	G			<b>3272 2R</b>	—
			D			<b>3273 7P</b>	—



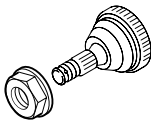
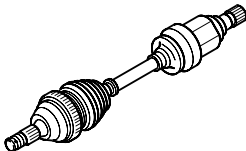

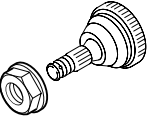
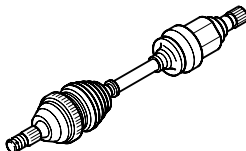

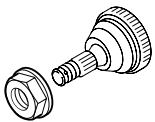
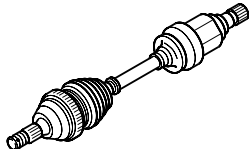

\* Livraison avec roue phonique 48 dents : Supplied with 48 tooth rotor - Vendida con rueda fonica 48 dientes - Entrega com roda fónica 48 dentes - Inkl. ABS-sensorzahnrad (48 zähne) - Venduta con ruota fonica 48 denti - Verkocht met phonisch wiel 48 tanden

 Electrique : Elctric - Elctrico - Elctrico - Elektrisch - Elettrico - Electrisch



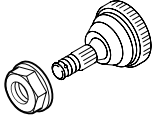
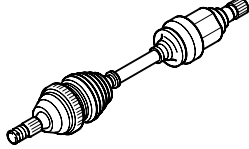



# CITROËN C3

<b>BV - MA</b>			G/D Repère	Neuve	E.S.
			(TU1JP-TU3JP) <b>Ess 1,1 L - 1,4 L</b>	 <b>3297 24</b> Ø 20 x 150 - H 28,5	G D
(TU5JP4) <b>Ess 1,6 L 16S</b>	 <b>3297 24</b> Ø 20 x 150 - H 28,5	G D	3272 EQ	-	
(DV4TD) <b>DI Turbo 1,4 L</b>	 <b>3297 24</b> Ø 20 x 150 - H 28,5	G D	3272 ES	-	
<b>BV - BE4R</b>			G/D Repère	Neuve	E.S.
			(DV4TED4) <b>DI Turbo 1,4 L 16S</b>	 <b>3297 24</b> Ø 20 x 150 - H 28,5	G D
<b>BVA - AL4</b>			G/D Repère	Neuve	E.S.
			(TU3JP) <b>Ess 1,4 L</b>	 <b>3297 24</b> Ø 20 x 150 - H 28,5	G D

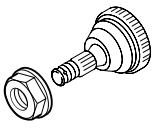
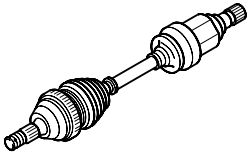



# CITROËN ZX

<b>BVA - MA</b>							
		G	D	Repère	Neuve	E.S.	
(TU1-TU1M-TU1M+) <b>Ess 1,1 L</b> (TU3.2-TU3M-TU3MC-TU3JP) <b>Ess 1,4 L</b>  (TU5JP) <b>Ess 1,6 L</b> (TUD3-TUD5) <b>DI Atmo 1,4 L - 1,5 L</b>		<b>3297 14</b>		G	8 HN 76	<b>3272 R7</b>	<b>95 669 013</b> → 04/95
		<b>3297 02</b>					D
		<b>3297 03</b>		D	8 JN 68	<b>3273 3Z</b>	
		<b>3297 00</b>					G
		Ø 20 x 150 - H 18				<b>3272 L6</b>	
(TU3M-TU3MC) <b>Ess 1,4 L IE Mono</b> 		<b>3297 00</b>		G	8 JN 67	<b>3272 1F</b>	<b>3272 L6</b>
		<b>3297 02</b>					D
		Ø 24 x 150 - H 13,5					
<b>BV - BE3/5 BVA - 4HP14</b>							
		G	D	Repère	Neuve	E.S.	
(XU5M-XU5JP-XU7JP-XU7JP4) <b>Ess 1,6 L - 1,8 L - 1,8 L 16S</b>  (XUD7-XUD9) <b>DI Atmo 1,8 L - 1,9 L</b>		<b>3297 00</b>		G	8 GN 04	<b>3272 A8</b>	<b>96 177 248</b>
		<b>3297 02</b>			8 GN 84		
		<b>3297 03</b>			8 GN 86		
		<b>3297 07°</b>			8 HN 92		
<b>3297 07°</b>		8 HN 98					
		Ø 24 x 150 - H 13,5					
(XU9JA-XU9JAZ) <b>Ess 1,9 L</b> 		<b>3297 00</b>		G	8 GN 04	<b>3272 A8</b>	<b>96 171 858</b>
		<b>3297 02</b>			8 GN 84		
		<b>3297 03</b>			8 GN 86		
		<b>3297 07°</b>			8 HN 92		
<b>3297 07°</b>		8 HN 98					
		Ø 24 x 150 - H 13,5					
		<b>3297 07°</b>		D	8 GN 05	<b>3273 K4</b>	<b>96 177 247</b>
		<b>3297 07°</b>			8 GN 85		
		<b>3297 07°</b>			8 GN 87		
		<b>3297 07°</b>			8 HN 93		
		<b>3297 07°</b>			8 HN 99		
		Ø 24 x 150 - H 20,2					
		<b>3297 07°</b>		D	8 GN 05	<b>3273 K4</b>	<b>96 171 861</b>
		<b>3297 07°</b>			8 GN 85		
		<b>3297 07°</b>			8 GN 87		
		<b>3297 07°</b>			8 HN 93		
		<b>3297 07°</b>			8 HN 99		
		Ø 24 x 150 - H 13,5					



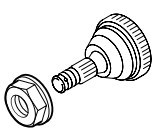
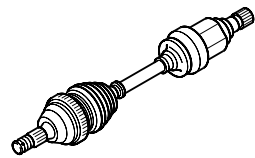







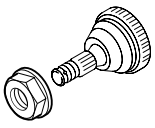
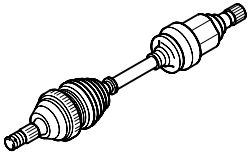











# CITROËN ZX

<b>BV - BE3/5</b> <b>BVA - 4HP14</b>							
		G / D	Repère	Neuve	E.S.		
(XU5M-XU5JP-XU7JP) <b>Ess 1,6 L - 1,8 L</b> (XU9JA-XU9JAZ) <b>Ess 1,9 L</b> (XUD7-XUD9) <b>DI Atmo 1,8 L - 1,9 L</b>		 <b>3297 00</b> <b>3297 02</b> <b>3297 03</b>	G	8 GN 82 8 JN 01 8 KN 71 8 KN 77	<b>3272 Y3</b>	<b>96 171 874</b> → 08/97 <b>3272 1N</b> 08/97 →	
			D	8 GN 81 8 GN 83 8 KN 73 8 KN 79	<b>3273 0R</b>	<b>96 171 875</b> → 08/97 <b>3273 6K</b> 08/97 →	
			Ø 24 x 150 - H 13,5				
(XU10J2) <b>Ess 2 L</b>		 <b>3297 00</b> <b>3297 02</b> <b>3297 03</b>	G	8 GN 82 8 JN 01 8 KN 71 8 KN 77	<b>3272 Y3</b>	<b>96 173 635</b>	
			D	8 GN 81 8 GN 83 8 KN 73 8 KN 79	<b>3273 0R</b>	<b>96 173 636</b>	
Ø 24 x 150 - H 13,5							
(XU10J2) <b>Ess 2 L</b>		 <b>3297 00</b> <b>3297 02</b> <b>3297 03</b>	G	8 GN 82 8 JN 01 8 KN 71 8 KN 77	<b>3272 Y3</b>	<b>96 173 637</b> → 08/97 <b>3272 1N</b> 08/97 →	
			D	8 GN 81 8 GN 83 8 KN 73 8 KN 79	<b>3273 0R</b>	<b>96 173 638</b> → 08/97 <b>3273 6K</b> 08/97 →	
Ø 24 x 150 - H 13,5							
(XU10J4) <b>Ess 2 L 16 S</b> → 08/96		 <b>3297 00</b> <b>3297 02</b> <b>3297 03</b>	G	8 GN 80 8 KN 72 8 KN 78	<b>3272 Z7</b>	<b>3272 A7</b>	
			D	8 GN 81 8 GN 83 8 KN 73 8 KN 79	<b>3273 0R</b>	<b>3273 K3</b>	
Ø 24 x 150 - H 13,5							
(XU10J4-XU10J4RS) <b>Ess 2 L 16 S</b> 08/96 →		 <b>3297 00</b> <b>3297 02</b> <b>3297 03</b>	G	8 KN 72 8 KN 78	<b>3272 Z7</b>	<b>3272 7S</b>	
			D	8 KN 73 8 KN 79	<b>3273 0R</b>	<b>3273 6J</b>	
Ø 24 x 150 - H 13,5							
(XU10J4-XU10J4RS) <b>Ess 2 L 16 S</b> 08/96 →		 <b>3297 00</b> <b>3297 02</b> <b>3297 03</b>	G	8 KN 72 8 KN 78	<b>3272 Z7</b>	<b>3272 8S</b>	
			D	8 KN 73 8 KN 79	<b>3273 0R</b>	<b>3273 6K</b>	
Ø 24 x 150 - H 13,5							









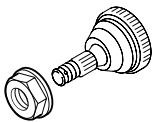
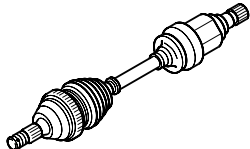

# CITROËN ZX

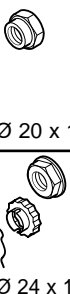
<b>CITROËN ZX</b>								
<b>BV - BE3/5 BVA - 4HP14</b>								
		<b>G</b>	<b>D</b>	<b>Repère</b>	<b>Neuve</b>	<b>E.S.</b>		
(XUD9TE) <b>DI Turbo 1,9 L</b>		 <b>3297 00</b> <b>3297 02</b> <b>3297 03</b>		<b>G</b>	8 GN 94	<b>3272 A9</b>	<b>96 171 856</b>	
		Ø 24 x 150 - H 13,5		<b>D</b>	8 GN 05 8 GN 85 8 GN 87 8 HN 93 8 HN 99	<b>3273 K4</b>	<b>96 171 857</b>	
(XUD9TE) <b>DI Turbo 1,9 L</b>		 <b>3297 00</b> <b>3297 02</b> <b>3297 03</b>		<b>G</b>	8 GN 80 8 KN 72 8 KN 78	<b>3272 Z7</b>	<b>3272 A7</b> → 08/97	
		Ø 24 x 150 - H 13,5		<b>D</b>	8 GN 81 8 GN 83 8 KN 73 8 KN 79	<b>3273 0R</b>	<b>3272 8S</b> 08/97 →	
							<b>3273 K3</b> → 08/97	
							<b>3273 6K</b> 08/97 →	











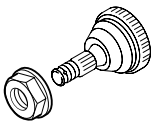
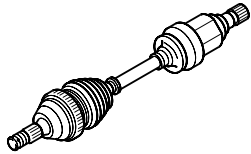









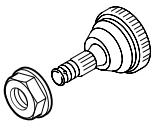
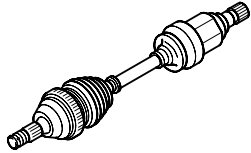



# CITROËN XSARA → 27/08/2000

<b>BV - MA</b>							
			G / D	Repère	Neuve	E.S.	
(TU3JP) Ess 1,4 L	→ 01/99	 BL	 <b>3297 14</b>	G		<b>3272 R7</b>	<b>3272 R8</b>
			Ø 20 x 150 - H 18	D		<b>3273 2Y</b>	<b>3273 2Z</b>
	01/99 →	 <b>3297 24</b>	G		<b>3272 7G</b>	<b>3272 3R</b>	
			Ø 20 x 150 - H 28,5	D		<b>3273 4T</b>	<b>3273 6G</b>
(TU3JP) Ess 1,4 L	→ 02/99	 BL	 <b>3297 00</b>	G		<b>3272 1F</b>	<b>3272 L6</b>
			 <b>3297 02</b>	D		<b>3273 3A</b>	<b>3273 3C</b>
		 <b>3297 03</b>	G		<b>3272 1F</b>	<b>3272 5W</b>	
	02/99 →	Ø 24 x 150 - H 13,5	D		<b>3273 3Z</b>	<b>3273 6H</b>	
(TU3JP) Ess 1,4 L	→ 01/99	 BK	 <b>3297 14</b>	G		<b>3272 0N</b>	<b>3272 0P</b>
			Ø 20 x 150 - H 18	D		<b>3273 2W</b>	<b>3273 2X</b>
	01/99 →	 <b>3297 00</b>	 <b>3297 02</b>	G		<b>3272 9G</b>	<b>3272 7L</b>
			 <b>3297 03</b>	D		<b>3273 4T</b>	<b>3273 6G</b>
(TU3JP) Ess 1,4 L	→ 02/98	 BK	 <b>3297 00</b>	G		<b>3272 Z2</b>	<b>3272 6L</b>
			 <b>3297 02</b>	D		<b>RP 3272 6F</b>	<b>3273 6F</b>
		 <b>3297 03</b>	G		<b>3273 2P</b>	<b>3273 6F</b>	
	02/98 →	Ø 24 x 150 - H 13,5	D		Avec Damper	Avec Damper	
			G		<b>3273 1C</b>	<b>3273 6E</b>	
			G		<b>3272 6F</b>	<b>3272 8L</b>	
			D		<b>3273 3Z</b>	<b>3273 6H</b>	
(TU5JP) 90 cv Ess 1,6 L	→ 03/98	 BL	 <b>3297 14</b>	G		<b>3272 9G</b>	<b>3272 5L</b>
			Ø 20 x 150 - H 18	D		<b>3273 4T</b>	<b>3273 6C</b>
	03/98 →	 <b>3297 00</b>	 <b>3297 02</b>	G		<b>3272 9G</b>	<b>3272 7L</b>
			 <b>3297 03</b>	D		<b>3273 4T</b>	<b>3273 6G</b>
		Ø 24 x 150 - H 13,5					

# CITROËN XSARA → 27/08/2000







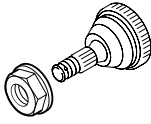
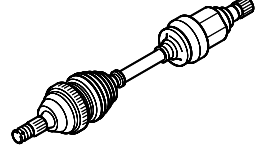

<b>BV - MA</b>						
		<b>G</b>	<b>D</b>	Repère	Neuve	E.S.
(TU5JP) 90 cv <b>Ess 1,6 L</b>	→ 11/98	 BL  11/98 → Ø 24 x 150 - H 13,5	G		3272 Z2 RP 3272 6F	3272 6L
			D		3273 1C	3273 6E
			G		3272 6F	3272 8L
			D		3273 3Z	3273 6H
(TU5JP) 90 cv <b>Ess 1,6 L</b>	→ 03/98	 BK  03/98 → Ø 20 x 150 - H 18 Ø 24 x 150 - H 13,5	G		3272 9G	3272 5L
			D		3273 4T	3273 6A
			G		3272 9G	3272 7L
			D		3273 4T	3273 6G
(TU5JP) 90 cv <b>Ess 1,6 L</b>	→ 02/98	 BK  02/98 → Ø 24 x 150 - H 13,5	G		3272 Z2 RP 3272 6F	3272 6L
			D		3273 2P	3273 6F
			G		3272 6F	3272 8L
			D		3273 3Z	3273 6H
(TUD5) <b>DI 1,5 L → 01/99</b>		 BL  Ø 20 x 150 - H 18	G		3272 R7	3272 R8
			D		3273 2Y	3273 Y3
(TUD5) <b>DI 1,5 L</b>	→ 02/99	 BL  02/99 → Ø 24 x 150 - H 13,5	G		3272 1F	3272 L6
			D		3273 3A	3273 3C
			G		3272 1F	3272 5W
			D		3273 3Z	3273 6H

# CITROËN XSARA → 27/08/2000

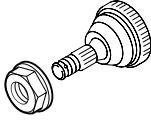
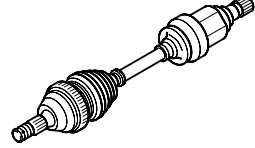









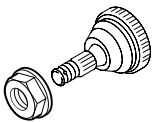
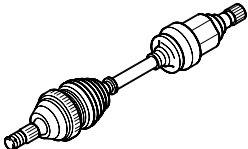











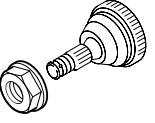
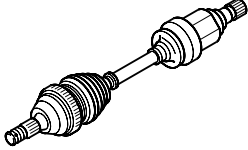





<b>BV - MA</b>			<b>G</b> <b>D</b>	Repère	Neuve	E.S.	
(TUD5) DI 1,5 L  → 03/98  BK   03/98 →	 <b>3297 14</b> Ø 20 x 150 - H 18   <b>3297 00</b>  <b>3297 02</b>  <b>3297 03</b> Ø 24 x 150 - H 13,5	<b>G</b>			<b>3272 9G</b>	<b>3272 5L</b>	
		<b>D</b>			<b>3273 4T</b>	<b>3273 6A</b>	
		<b>G</b>			<b>3272 9G</b>	<b>3272 7L</b>	
		<b>D</b>			<b>3273 4T</b>	<b>3273 6G</b>	
(TUD5) DI 1,5 L  → 02/98  BK   02/98 →	 <b>3297 00</b>  <b>3297 02</b>  <b>3297 03</b> Ø 24 x 150 - H 13,5	<b>G</b>			<i>3272 Z2</i> RP <b>3272 6F</b>	<b>3272 6L</b>	
		<b>D</b>			<b>3273 1C</b>	<b>3273 6E</b>	
		<b>G</b>			<b>3272 6F</b>	<b>3272 8L</b>	
		<b>D</b>			<b>3273 3Z</b>	<b>3273 6H</b>	
<b>BV - BE3</b>			<b>G</b> <b>D</b>	Repère	Neuve	E.S.	
(XU7JB-XU7JP-XU7JP4) <b>Ess 1,8 L - 1,8 L 16 S</b> (XUD7-XUD9-DW8) <b>DI 1,8 L - 1,9 L</b> (XUD9BSD) <b>DI Turbo 1,9 L</b>	 <b>3297 12</b>  <b>3297 13</b>  <b>3297 03</b> Ø 24 x 150	<b>G</b>		8 KN 71 8 KN 77	<b>3272 Y3</b>	<b>3272 9L</b> 	
		<b>D</b>			<b>3273 0R</b>	<b>3272 1N</b> 	
		<b>D</b>			8 KN 73 8 KN 79	<b>3273 0R</b>	<b>3273 6J</b> 
		<b>D</b>			8 KN 73 8 KN 79	<b>3273 0R</b>	<b>3273 6K</b> 
(XU10J4R-XU10J4RS) <b>Ess 2 L 16 S</b> (XUD9TE-DW10TD) <b>DI Turbo 1,9 L - 2 L HDi</b>	 <b>3297 00</b>  <b>3297 02</b>  <b>3297 03</b> Ø 24 x 150 - H 13,5	<b>G</b>		8 KN 72 8 KN 78	<b>3272 Z7</b>	<b>3272 7S</b> 	
		<b>D</b>			<b>3273 0R</b>	<b>3272 8S</b> 	
		<b>D</b>			8 KN 73 8 KN 79	<b>3273 0R</b>	<b>3273 6J</b> 
		<b>D</b>			8 KN 73 8 KN 79	<b>3273 0R</b>	<b>3273 6K</b> 



# CITROËN XSARA → 27/08/2000

<b>BVA - AL4</b>			<b>G</b>	<b>D</b>	<b>Repère</b>	<b>Neuve</b>	<b>E.S.</b>
(TU5JP) 90 cv <b>Ess 1,6 L</b> (XU10J4R) <b>Ess 2 L 16 S</b>	  <b>3297 00</b> <b>3297 02</b> <b>3297 03</b> Ø 24 x 150 - H 13,5	<b>G</b>		8 LN 33 8 LN 37	<b>3272 1G</b>	<b>3272 2G</b>	
		<b>D</b>		8 LN 34 8 LN 38	<b>3273 4L</b> → 04/2000	<b>3273 4N</b> → 04/2000	
				8 MN 03	<b>3273 9T</b> 04/2000 →	<b>3273 9V</b> 04/2000 →	
<b>BVA - 4HP14</b>			<b>G</b>	<b>D</b>	<b>Repère</b>	<b>Neuve</b>	<b>E.S.</b>
(XU7JB-XU7JP) <b>Ess 1,8 L</b> (XU7JP4) <b>Ess 1,8 L 16 S</b>	  <b>3297 12</b> <b>3297 13</b> <b>3297 03</b> Ø 24 x 150	<b>G</b>		8 KN 71 8 KN 77	<b>3272 Y3</b>	<b>3272 9L</b> 	
		<b>D</b>		8 KN 73 8 KN 79	<b>3273 0R</b>	<b>3272 1N</b> 	
						<b>3273 6J</b> 	
						<b>3273 6K</b> 	

# CITROËN XSARA 28/08/2000 →

<b>BV - MA</b>								
		G	D	Repère	Neuve	E.S.		
(TU3JP) <b>Ess 1,4L</b> Differentiel 70				3297 00 3297 02 3297 03 Ø 24 x 150 - H 13,5	G	3272 1F	3272 5W	
				D	3273 3Z	3273 6H		
(TU3JP - TU5JP4) <b>Ess 1,4L - 1,6 L 16 S</b> Differentiel 77				3297 00 3297 02 3297 03 Ø 24 x 150 - H 13,5	G	3272 9G	3272 7L	
				D	3273 4T	3273 6G		
(TU3JP - TU5JP4) <b>Ess 1,4L - 1,6 L 16 S</b> Sans système ESP				3297 00 3297 02 3297 03 Ø 24 x 150 - H 13,5	G	3272 6F	3272 8L	
				D	3273 3Z	3273 6H		
(TU5JP4) <b>Ess 1,6L 16 S</b> Avec système ESP				3297 00 3297 02 3297 03 Ø 24 x 150 - H 13,5	G	3272 FE	3272 FF	
				D	3273 FE	3273 FF		
<b>BV - BE4R</b>								
		G	D	Repère	Neuve	E.S.		
(EW10J4 - XU10J4RS) <b>Ess 2 L 16 S</b> Sans système ESP				3297 00 3297 02 3297 03 Ø 24 x 150 - H 13,5	G	8 KN 72 8 KN 78	3272 Z7	3272 8S
				D	8 KN 73 8 KN 79	3273 0R	3273 6K	
(EW10J4 ) <b>Ess 2 L 16 S</b> Avec système ESP				3297 00 3297 02 3297 03 Ø 24 x 150 - H 13,5	G	8 MN 49	3272 FG	3272 FH
				D	8 MN 50	3273 FG	3273 FH	
(DW8B) <b>DI Atmo 1,9 L</b>				3297 00 3297 02 3297 03 Ø 24 x 150 - H 13,5	G	8 KN 71 8 KN 77	3272 Y3	3272 1N
				D	8 KN 73 8 KN 79	3273 0R	3273 6K	
(DW10TD - DW10ATED) <b>DI Turbo 2 L HDi</b> Sans système ESP				3297 00 3297 02 3297 03 Ø 24 x 150 - H 13,5	G	8 KN 72 8 KN 78	3272 Z7	3272 8S
				D	8 KN 73 8 KN 79	3273 0R	3273 6K	
(DW10ATED) <b>DI Turbo 2 L HDi</b> Avec système ESP				3297 00 3297 02 3297 03 Ø 24 x 150 - H 13,5	G	8 MN 49	3272 FG	3272 FH
				D	8 MN 50	3273 FG	3273 FH	



Differentiel 70 : Differentil 70 - Diferencial 70 - Diferencial 70 - Differential 70 - Differenziale 70 - Differentieel 70

Differentiel 77 : Differentil 77 - Diferencial 77 - Diferencial 77 - Differential 77 - Differenziale 77 - Differentieel 70



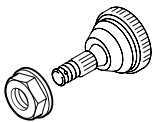
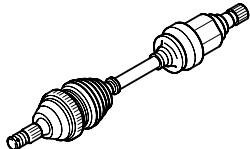

Sans système ESP : Without ESP - Sin sistema ESP - Sem sistema ESP - Ohne system ESP - Senza sistema ESP - Zonder ESP

Avec système ESP : With ESP - Con sistema ESP - Con sistema ESP - Mit system ESP - Con sistema ESP - Met ESP



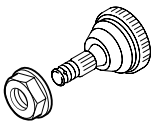
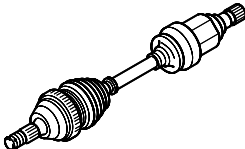

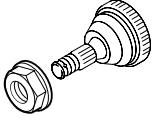
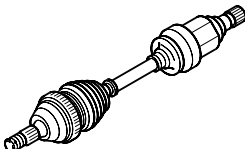

# CITROËN XSARA 28/08/2000 →

<b>BVA - AL4</b>					
		G/D	Repère	Neuve	E.S.
(TU5JP4 - EW10J4) <b>Ess 1,6 L 16 S - 2 L 16 S</b>  (DW10ATED) <b>DI Turbo 2 L HDi</b>  Sans système ESP	 <b>3297 00</b> <b>3297 02</b> <b>3297 03</b>  R  Ø 24 x 150 - H 13,5	G	8 LN 33 8 LN 37	<b>3272 1G</b>	<b>3272 2G</b>
		D	8 MN 03	<b>3273 9T</b>	<b>3273 9V</b>
(TU5JP4 - EW10J4) <b>Ess 1,6 L 16 S - 2 L 16 S</b>  (DW10ATED) <b>DI Turbo 2 L HDi</b>  Avec système ESP	 <b>3297 00</b> <b>3297 02</b> <b>3297 03</b>  R  Ø 24 x 150 - H 13,5	G	8 MN 51	<b>3272 FG</b>	<b>3272 FK</b>
		D	8 MN 52	<b>3273 FG</b>	<b>3273 FK</b>

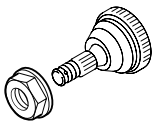
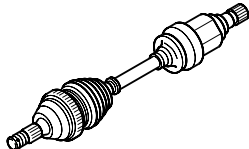

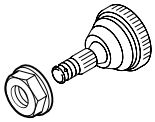
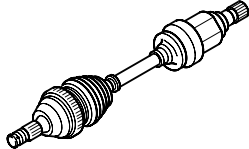

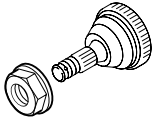
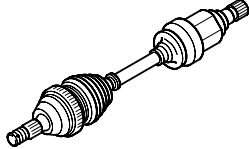

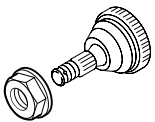
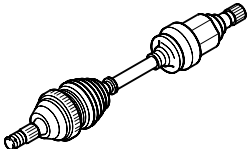

# CITROËN XSARA PICASSO

<b>BV - BE4R</b>						
		G	D	Repère	Neuve	E.S.
(TU5JP) <b>Ess 1,6 L</b>  (EW7J4) <b>Ess 1,8 L 16 S</b>	 <b>3297 00</b> <b>3297 02</b> <b>3297 03</b>  Ø 24 x 150 - H 13,5	<b>G</b>	8 LN 64	3272 8R	<b>3272 9R</b>	
			8 LN 61	RP 3272 Y3 → 01/2000		
		<b>D</b>	8 KN 71	<b>3272 Y3</b>	<b>3273 1N</b>	
			8 KN 77	01/2000 →		
<b>D</b>	8 LN 66	3273 7W	<b>3273 7X</b>			
	8 LN 63	RP 3273 0R → 01/2000				
<b>D</b>	8 KN 73	<b>3273 0R</b>	<b>3273 6K</b>			
	8 KN 79	01/2000 →				
(EW10J4) <b>Ess 2 L 16 S</b>	 <b>3297 00</b> <b>3297 02</b> <b>3297 03</b>  Ø 24 x 150 - H 13,5	<b>G</b>	8 KN 72	<b>3272 Z7</b>	<b>3272 8S</b>	
		8 KN 78	<b>D</b>	8 KN 73		<b>3273 0R</b>
8 KN 79	<b>D</b>	8 LN 65		3272 1S	<b>3272 2S</b>	
8 LN 62		RP 3272 Z7 → 01/2000	<b>3272 8S</b>			
8 KN 72	<b>D</b>	8 KN 72		<b>3272 Z7</b>		
8 KN 78		01/2000 →	<b>3273 8S</b>			
8 LN 66	<b>D</b>	8 LN 66		3273 7W	<b>3273 7X</b>	
8 LN 63		RP 3273 0R → 01/2000				
8 KN 73	<b>D</b>	8 KN 73	<b>3273 0R</b>	<b>3273 6K</b>		
8 KN 79		01/2000 →				
<b>BVA - AL4</b>						
		G	D	Repère	Neuve	E.S.
(EW10J4) <b>Ess 2 L 16 S</b>	 <b>3297 00</b> <b>3297 02</b> <b>3297 03</b>  Ø 24 x 150 - H 13,5	<b>G</b>	8 MN 51	<b>3272 FJ</b>	<b>3272 FK</b>	
		<b>D</b>	8 MN 52	<b>3273 FJ</b>		<b>3273 FK</b>





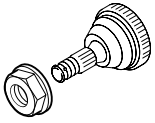
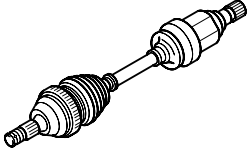





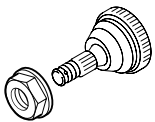
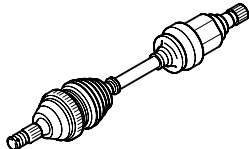





# CITROËN BX

<b>CITROËN BX</b>				
<b>BV - BH3</b>				
			<b>G/D</b>	<b>Repère</b>
			<b>Neuve</b>	<b>E.S.</b>
(XW7) <b>Ess 1,1 L (I) (GR) → 05/88</b> (XY7) <b>Ess 1,4 L → 05/88</b>	 <b>3297 00</b> <b>3297 02</b> <b>3297 03</b> <small>Ø 24 x 150 - H 13,5</small>	<b>G/D</b> 8 GN 25 ou 8 GN 28	<b>NFP</b>	<b>NFP</b> → 04/84 <b>95 619 478</b> 04/84 →
<b>BV - MA</b>				
			<b>G/D</b>	<b>Repère</b>
			<b>Neuve</b>	<b>E.S.</b>
(TU1) <b>Ess 1,1 L (I) (GR) → 05/88</b> (TU3) <b>Ess 1,4 L → 05/88</b>	 <b>3297 00</b> <b>3297 02</b> <b>3297 03</b> <small>Ø 24 x 150 - H 13,5</small>	<b>G</b> 8 GN 48 8 JN 67  <b>D</b> 8 GN 49 8 JN 68	<b>3272 1F</b>	<b>95 655 262</b>
			<b>3273 3Z</b>	<b>95 655 261</b>
<b>BV - BE1 - BE3</b>				
			<b>G/D</b>	<b>Repère</b>
			<b>Neuve</b>	<b>E.S.</b>
(XU5-XU9JA) <b>Ess 1,6 L 1,9 L</b>	 <b>3297 00</b> <b>3297 02</b> <b>3297 03</b> <small>Ø 24 x 150 - H 13,5</small>	<b>G</b> 8 GN 04 8 GN 84 8 GN 86 8 HN 92 8 HN 98  <b>D</b> 8 GN 05 8 GN 85 8 GN 87 8 HN 93 8 HN 99	<b>3272 A8</b>	<b>95 606 796 NFP</b> → 03/84 <b>95 624 470</b> <b>1,9L i</b> <b>95 619 479</b> 03/84 → 06/87 <b>3272 2N</b> 06/87 →
			<b>3273 K4</b>	<b>95 606 797 NFP</b> → 03/84 <b>95 624 471</b> <b>1,9L i</b> <b>95 619 480</b> 03/84 → 06/87 <b>3273 6L</b> 06/87 →

# CITROËN BX

<b>BV - BE1 - BE3</b>							
		G	D	Repère	Neuve	E.S.	
(XUD7-XUD9) DI 1,8 L - 1,9 L			3297 00 3297 02 3297 03	G	8 GN 04 8 GN 84 8 GN 86 8 HN 92 8 HN 98	3272 A8	95 606 796 NFP → 03/84
				D	8 GN 05 8 GN 85 8 GN 87 8 HN 93 8 HN 99	3273 K4	95 619 479 03/84 → 06/87
						3272 2N 06/87 →	95 606 797 NFP → 03/84
						3273 6L 06/87 → 01/93	96 173 636 01/93 →
		Ø 24 x 150 - H 13,5					
(XUD7TE) DI Turbo 1,8 L			3297 00 3297 02 3297 03	G	8 GN 04 8 GN 84 8 GN 86 8 HN 92 8 HN 98	3272 A8	95 624 470 → 01/93
				D	8 GN 05 8 GN 85 8 GN 87 8 HN 93 8 HN 99	3273 K4	96 173 635 01/93 →
						95 624 471 → 01/93	96 173 636 01/93 →
						3273 K8 01/94 →	
		Ø 24 x 150 - H 13,5					
TT Ess - Diesel			3297 00 3297 02 3297 03	G	8 GN 41	3272 C3	95 624 472 → 12/93
				D	8 GN 42	3273 K7	3272 C5 01/94 →
						95 624 473 → 12/93	3273 K8 01/94 →
		Ø 24 x 150 - H 13,5					
<b>BV - BE3 - 4x4</b>							
		G	D	Repère	Neuve	E.S.	
4 x4 Ess - Diesel 1,9 L	Transmission AV		3297 00 3297 02 3297 03	G	8 GN 61 8 GN 63	NFP	3272 T1
				D	8 GN 62 8 GN 64	NFP	3273 1L
4 x4 Ess - Diesel 1,9 L	Transmission AR	Ø 24 x 150 - H 13,5		G/D	8 GN 67 8 GN 68	3274 A8	-

# CITROËN XANTIA





<b>BV - BE3 BVA - 4HP14</b>							
		G	D	Repère	Neuve	E.S.	
(XU5JP-XU7JP-XU10J2) <b>Ess 1,6 L - 1,8 L - 2 L → 05/95</b>  (XUD9A) <b>DI Atmo 1,9 L → 05/95</b>		 <b>3297 00</b> <b>3297 02</b> <b>3297 03</b>	 R Ø 24 x 150 - H 13,5	G	8 HN 71 8 HN 80 8 HN 84	<b>96 141 635</b>	<b>3272 G8</b> → 06/94
				D	8 JN 32 8 JN 33 8 JN 34	<b>96 164 213</b>	<b>3273 P3</b>
(XU10J4) <b>Ess 2 L 16 S → 06/94</b>  (XUD9TE) <b>DI Turbo 1,9 L → 06/94</b>		 <b>3297 00</b> <b>3297 02</b> <b>3297 03</b>	 R Ø 24 x 150 - H 13,5	G	8 HN 82 8 HN 86	<b>96 141 637</b>	<b>3272 G9</b>
				D	8 JN 32 8 JN 33 8 JN 34	<b>96 164 213</b>	<b>3273 P3</b>
(XU5JP-XU7JP-XU10J2) <b>Ess 1,6 L - 1,8 L - 2 L 07/94 → 05/95</b>  (XUD9A) <b>DI Atmo 1,9 L 07/94 → 05/95</b>		 <b>3297 00</b> <b>3297 02</b> <b>3297 03</b>	 R Ø 24 x 150 - H 13,5	G	8 KN 34 8 KN 36 8 KN 39	<b>3272 Q3 ••</b>	<b>3272 Q9 •</b>
				D	8 KN 38 8 KN 41	<b>3273 W8 ••</b>	<b>3273 X3 •</b> <b>3273 W9 ••</b>
(XU10J4) <b>Ess 2 L 16S 07/94 → 05/95</b>  (XUD9TE) <b>DI Turbo 1,9 L 07/94 → 05/95</b>		 <b>3297 00</b> <b>3297 02</b> <b>3297 03</b>	 R Ø 24 x 150 - H 13,5	G	8 KN 35	<b>3272 Q7 •</b>	<b>3272 R0 •</b>
				D	8 KN 38 8 KN 41	<b>3273 W8 ••</b>	<b>3273 X3 •</b> <b>3273 W9 ••</b>
(XU5JP-XU7JP-XU7JB-XU7JP4-XU10J2) <b>Ess 1,6 L - 1,8 L 16 S - 2 L 08/95 →</b> (XUD9A) <b>DI Atmo 1,9 L 08/95 →</b> (XUD9SD) <b>DI Turbo 1,9 L SD</b>		 <b>3297 00</b> <b>3297 02</b> <b>3297 03</b>	 R Ø 24 x 150 - H 13,5	G	8 KN 34 8 KN 36 8 KN 39	<b>3272 Q3 ••</b>	<b>3272 Q4 ••</b>
				D	8 KN 38 8 KN 41	<b>3273 W8 ••</b>	<b>3273 W9 ••</b>
(XU10J4R) <b>Ess 2 L 16 S 08/95 →</b> (XUD9TE) <b>DI Turbo 1,9 L 08/95 →</b> (DW10TD) <b>DI Turbo 2 L HDi</b>	<b>Sans suspension hydractive</b>	 <b>3297 00</b> <b>3297 02</b> <b>3297 03</b>	 R Ø 24 x 150 - H 13,5	G	8 KN 37 8 KN 40	<b>3272 Q5 ••</b>	<b>3272 Q6 ••</b>
				D	8 KN 38 8 KN 41	<b>3273 W8 ••</b>	<b>3273 W9 ••</b>

• **Arbres pleins** : Solid shafts - Veios cheios - Veios maciços - Antriebswellen massiv - Alberi pieni - Massieve assen

•• **Arbres tubulaires** : Hollow shafts - Veios tubulares - Veios tubulares - Antriebswellen hohl - Alberi tubolari - buisvorviige assen

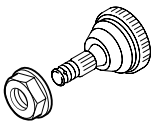
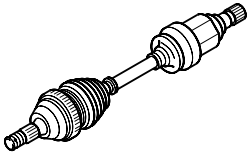
**Sans suspension hydractive** : Without suspension hydractive - Sin suspension hydractiva - Sem suspensão hidractiva - Ohne hydractiv federung - Senza sosensione dell'idrattiva - Zonder vering hydractief

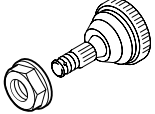
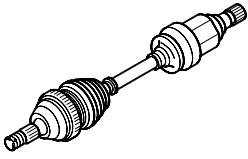
# CITROËN XANTIA

<b>BV - BE3 BVA - 4HP14</b>						
		G/D	Repère	Neuve	E.S.	
(XU10J4R) <b>Ess 2 L 16 S</b>  → 01/98 <b>Suspension hydractive</b>  01/98 →	 <b>3297 00</b> <b>3297 02</b> <b>3297 03</b>	G	8 KN 35	<b>3272 Q7 •</b>	<b>3272 R0 •</b>	
		D	8 KN 38 8 KN 41	<b>3273 W8 ••</b>	<b>3273 W9 ••</b>	
		G	8 LN 10	<b>3272 5A</b>	<b>3272 6A</b>	
		D	8 LN 11	<b>3273 2J</b>	<b>3273 2K</b>	
Ø 24 x 150 - H 13,5						
<b>BV - ML5T</b>						
		G/D	Repère	Neuve	E.S.	
(XU10J2TE-ES9J4) <b>Ess 2 L Turbo - V6 3 L</b> (XUD11BTE) <b>DI Turbo 2,1 L</b> (DW10ATED) <b>DI Turbo 2 L HDi</b>	 <b>3297 00</b> <b>3297 02</b> <b>3297 03</b>	G	KN 44	<b>3272 T5</b>	<b>3272 T6</b>	
		D	KN 45	<b>3273 Z7</b>	<b>3273 Z8</b>	
Ø 24 x 150 - H 13,5						
(XU10J2TE-ES9J4) <b>Ess 2 L Turbo - V6 3 L</b> (XUD11BTE) <b>DI Turbo 2,1 L</b>	 <b>3297 00</b> <b>3297 02</b> <b>3297 03</b>	G	KN 33 KN 83 KN 84	<b>3273 Z9</b>	-	
		D	KN 45	<b>3273 Z7</b>	<b>3273 Z8</b>	
Ø 24 x 150 - H 13,5						

• Arbres pleins : Solid shafts - Veios cheios - Veios maciços - Antriebswellen massiv - Alberi pieni - Massieve assen









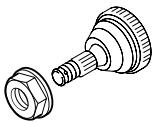
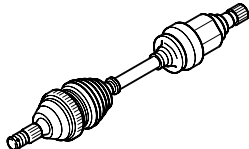

•• Arbres tubulaires : Hollow shafts - Veios tubulares - Veios tubulares - Antriebswellen hohl - Alberi tubolari - buisvorviège assen

Suspension hydractive : Suspension hydractive - Suspensie hydractiva - Suspensieo hidractiva - hydractiv federung - Sosensione dell'idrattiva - Vering hydractief

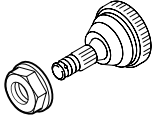
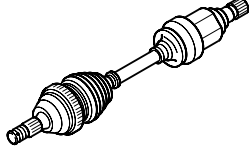





Sans suspension hydractive : Without suspension hydractive - Sin suspensieo hidractiva - Sem suspensieo hidractiva - Ohne hydractiv federung - Senza sosensione dell'idrattiva - Zonder vering hydractief

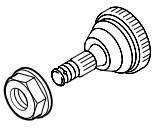
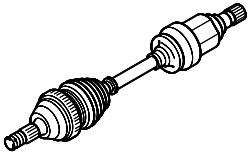

# CITROËN XANTIA

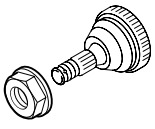
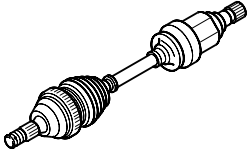
<b>BVA - 4HP20</b>								
		G	D	Repère	Neuve	E.S.		
(ES9J4) Ess V6 3 L	 <b>3297 00</b>  <b>3297 02</b>  <b>3297 03</b> Ø 24 x 150 - H 13,5	G		8 KN 93	<b>3272 0K</b>	<b>3272 0L</b>		
			D		8 KN 94	<b>3273 1N</b>	<b>3273 1P</b>	
<b>BVA - AL4</b>								
		G	D	Repère	Neuve	E.S.		
<b>Sans suspension hydractive</b>  (XU7JP4-XU10J4R) <b>Ess 1,8 L 16 S - 2 L 16 S</b>  <b>Avec suspension hydractive</b>	 <b>3297 00</b>  <b>3297 02</b>  <b>3297 03</b> Ø 24 x 150 - H 13,5	G		8 LN 04 8 LN 45	<b>3272 4H</b>	<b>3272 2A</b> → 04/2000 <b>3272 4W</b> 04/2000 →		
			D		8 LN 05 8 LN 46	<b>3273 4X</b> → 04/2000	<b>3273 2F</b> → 04/2000	
					8 MN 10	<b>3273 9G</b> 04/2000 →	<b>3273 9H</b> 04/2000 →	
				G		8 LN 08	<b>3272 6G</b>	<b>3272 4A</b>
				D		8 LN 09	<b>3273 4R</b>	<b>3273 2H</b>
		(XUD9TE) <b>DI Turbo 1,9 L</b>	 <b>3297 00</b>  <b>3297 02</b>  <b>3297 03</b> Ø 24 x 150 - H 13,5	G		8 LN 08 8 LN 49	<b>3272 6G</b>	<b>3272 4A</b>
D					8 LN 09 8 LN 50	<b>3273 4R</b> → 04/2000	<b>3273 2H</b>	
					8 MN 11	<b>3273 9W</b> 04/2000 →	<b>3273 9Y</b>	

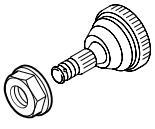
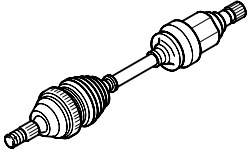
# CITROËN C5

<b>BV - BE4R</b>					
		G / D	Repère	Neuve	E.S.
(EW7J4) Ess 1,8 L 16 S	 <b>3297 00</b> <b>3297 02</b> <b>3297 03</b> Ø 24 x 150 - H 13,5	G	8 LN 81	<b>3272 4T</b>	-
		D	8 LN 80	<b>3273 8G</b>	-
(EW10D - EW10J4) Ess 2 L - 2 L 16 S (DW10TD) DI Turbo 2 L HDi	 <b>3297 00</b> <b>3297 02</b> <b>3297 03</b> Ø 24 x 150 - H 13,5	G	8 LN 82	<b>3272 6T</b>	-
		D	8 LN 80	<b>3273 8G</b>	-
<b>BV - ML5T</b>					
		G / D	Repère	Neuve	E.S.
(ES9J4S) Ess V6 3L (DW10ATED) DI Turbo 2 L HDi	 <b>3297 00</b> <b>3297 02</b> <b>3297 03</b> Ø 24 x 150 - H 13,5	G		<b>3272 EJ</b>	-
		D		<b>3273 EJ</b>	-
(DW12TED4) DI Turbo 2,2 L HDi 16 S	 <b>3297 00</b> <b>3297 02</b> <b>3297 03</b> Ø 24 x 150 - H 13,5	G		<b>3272 EH</b>	-
		D		<b>3273 EH</b>	-
<b>BVA - 4HP20</b>					
		G / D	Repère	Neuve	E.S.
(ES9J4S) Ess V6 3L	 <b>3297 00</b> <b>3297 02</b> <b>3297 03</b> Ø 24 x 150 - H 13,5	G		<b>3272 EL</b>	-
		D		<b>3273 EL</b>	-
(DW12TED4) DI Turbo 2,2 L HDi 16 S	 <b>3297 00</b> <b>3297 02</b> <b>3297 03</b> Ø 24 x 150 - H 13,5	G		<b>3272 EK</b>	-
		D		<b>3273 EK</b>	-



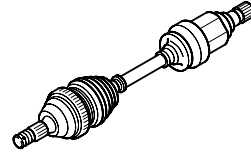
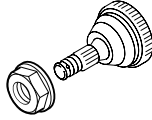

# CITROËN C5

## BVA - AL4



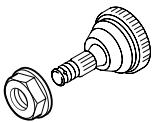
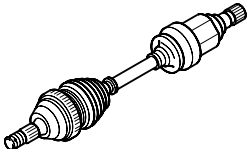

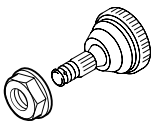
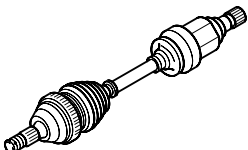





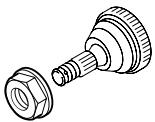
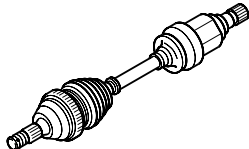

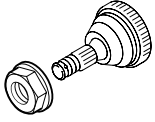
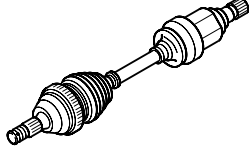

		G / D		Repère	Neuve	E.S.
		(EW7J4 - EW10J4) Ess 1,8 L 16 S - 2 L 16 S (DW10ATED) DI Turbo 2 L HDi	 3297 00 3297 02 3297 03 R	G	D	8 LN 84
	Ø 24 x 150 - H 13,5	D		8 LN 99	3273 8W	-



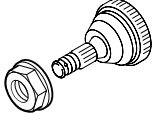
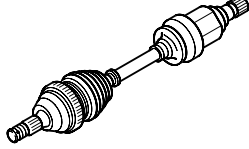

# CITROËN XM

<b>BV - BE3 -BE5</b>					
		G <span style="border-left: 1px solid black; border-right: 1px solid black; padding: 0 5px;">D</span> Repère	Neuve	E.S.	
(XU102C-XU10M-XU10J2-XU10J4R) <b>Ess 2 L - 2 L 16 S</b> (XUD11A) <b>DI Atmo 2,1 L</b>	 <b>3297 00</b> <b>3297 02</b> <b>3297 03</b>	<b>G</b>	8 GN 57 8 GN 59	<b>3272 P8</b>	<b>3272 3N</b> → 01/93 <b>3272 E8</b> <b>RP 3272 4S</b> 01/93 →
		<b>D</b>	8 GN 58 8 GN 60	<b>3273 W3</b> <b>RP 3273 H8</b>	<b>3273 6N</b> → 01/93 <b>3273 9X</b> <b>RP 3273 W4</b> 01/93 →
	Ø 24 x 150 - H 13,5				
<b>BV - ME5T</b> <b>BVA - 4HP18</b>					
		G <span style="border-left: 1px solid black; border-right: 1px solid black; padding: 0 5px;">D</span> Repère	Neuve	E.S.	
(XU10J2-XU10J2TE) <b>Ess 2 L IE - 2 L IE Turbo</b> → 07/94 (ZJP-ZJP4) <b>Ess 3 L V6</b> → 07/94 (XUD11ATE) <b>DI Turbo 2,1 L</b> → 07/94	 <b>3297 00</b> <b>3297 02</b> <b>3297 03</b>	<b>G</b>	8 GN 53/55 8 GN 91 8 HN 31 8 JN 41/44 8 JN 45/46 8 JN 75/77 8 KN 50/54	<b>3272 N0</b>	<b>3272 5N</b>
		<b>D</b>	8 GN 54/56 8 HN 32 8 JN 40/42 8 JN 43/49 8 JN 76/78 8 KN 51/55	<b>3273 T6</b>	<b>3273 6P</b>
	Ø 24 x 150 - H 13,5				
(XU10J2TE) <b>Ess 2 L IE Turbo</b> 07/94 → (XU10J4R) <b>Ess 2 L 16 S</b> 07/94 → (ZPJ) <b>Ess 3 L V6</b> 07/94 → (XUD11ATE - XUD11BTE) <b>DI Turbo 2,1 L</b> 07/94 →	 <b>3297 00</b> <b>3297 02</b> <b>3297 03</b>	<b>G</b>	8 GN 53/55 8 GN 91 8 HN 31 8 JN 41/44 8 JN 45/46 8 JN 75/77 8 KN 50/54	<b>3272 N0</b>	<b>3272 N2</b>
		<b>D</b>	8 GN 54/56 8 HN 32 8 JN 40/42 8 JN 43/49 8 JN 76/78 8 KN 51/55	<b>3273 T6</b>	<b>3273 T8</b>
	Ø 24 x 150 - H 13,5				

# CITROËN XM

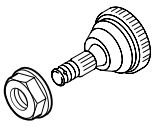
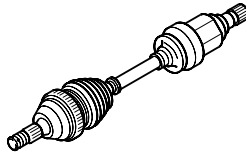
<b>CITROËN XM</b>						
<b>BV - MG5T</b>			<b>G</b> / <b>D</b>	<b>Repère</b>	<b>Neuve</b>	<b>E.S.</b>
(ZPJ-ZPJ4) <b>Ess V6 3 L</b>	 <b>3297 00</b>		<b>G</b>	8 JN 92	<b>3272 P3</b>	<b>3272 P4 ••</b> <b>3272 N8 •</b>
(DK5ATE) <b>DI Turbo 2,5 L</b>	 <b>3297 02</b>					
	 <b>3297 03</b> Ø 24 x 150 - H 13,5		<b>D</b>	8 JN 93	<b>3273 V8</b>	<b>3273 V9 ••</b> <b>3273 V4 •</b>
<b>BV - ML5T</b>			<b>G</b> / <b>D</b>	<b>Repère</b>	<b>Neuve</b>	<b>E.S.</b>
(ES9J4) <b>Ess V6 3 L</b>	 <b>3297 00</b>		<b>G</b>	8 KN 97	<b>3272 0T</b>	<b>3272 0V</b>
	 <b>3297 02</b>					
	 <b>3297 03</b> Ø 24 x 150 - H 13,5		<b>D</b>	8 KN 98	<b>3273 1W</b>	<b>3273 1X</b>
<b>BVA - 4HP20</b>			<b>G</b> / <b>D</b>	<b>Repère</b>	<b>Neuve</b>	<b>E.S.</b>
(ES9J4) <b>Ess V6 3 L</b>	 <b>3297 00</b>		<b>G</b>	8 KN 95	<b>3272 0R</b>	<b>3272 0S</b>
	 <b>3297 02</b>					
	 <b>3297 03</b> Ø 24 x 150 - H 13,5		<b>D</b>	8 KN 96	<b>3273 1T</b>	<b>3273 1V</b>

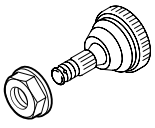
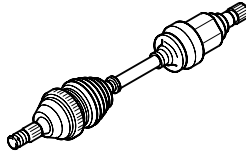
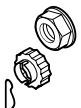
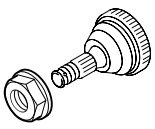
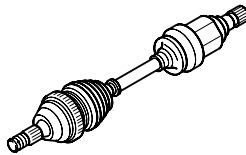
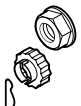
# CITROËN EVASION

<b>BV - BE3/5 BV - BE3R - BE4R</b>					
		G / D	Repère	Neuve	E.S.
(XU7JP-XU10J2) <b>Ess 1,8 L - 2 L</b>	 <b>3297 12</b> <b>3297 13</b>	G	8 JN 69 8 JN 71	<b>3272 L1</b>	<b>3272 1L</b>
(EW10J4) <b>Ess 2 L 16 S</b>		D	8 JN 70 8 JN 72	<b>3273 V7</b>	<b>3273 5X</b>
	Ø 24 x 150 - H 13,5				
<b>BV - ME</b>					
		G / D	Repère	Neuve	E.S.
(XU10J2TE) <b>Ess 2 L Turbo →12/96</b>	 <b>3297 12</b> <b>3297 13</b> <b>3297 03</b>	G	8 JN 53 8 JN 55 8 KN 85 8 KN 87	<b>3272 V0</b>	<b>3272 2L</b>
(XUD9TE) <b>DI Turbo 1,9 L → 04/96</b>		D	8 JN 54 8 JN 56 8 KN 86 8 KN 88	<b>3273 06</b>	<b>3273 5Y</b>
	Ø 24 x 150 - H 13,5				
<b>BV - ML5T</b>					
		G / D	Repère	Neuve	E.S.
(XU10J2TE) <b>Ess 2 L Turbo 12/96 →</b>	 <b>3297 12</b> <b>3297 13</b> <b>3297 03</b>	G	8 JN 53 8 JN 55 8 KN 85 8 KN 87	<b>3272 V0</b>	<b>3272 2L</b> → 12/96
(XU10J4R) <b>Ess 2 L 16 S</b>		D	8 JN 54 8 JN 56 8 KN 86 8 KN 88	<b>3273 06</b>	<b>3272 3L</b> 12/96 →
(XUD9TE) <b>DI Turbo 1,9 L 04/96 →</b>	 <b>3297 00</b> <b>3297 02</b> <b>3297 03</b>	G	8 LN 42 8 LN 44	<b>3272 9C</b>	<b>3272 2E</b> RP <b>3272 4L</b>
(XUD11BTE) <b>DI Turbo 2,1 L</b>		D	8 LN 41 8 LN 43	<b>3273 3Q</b>	<b>3273 5Z</b>
	Ø 24 x 150 - H 13,5				





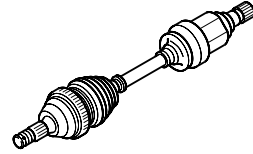
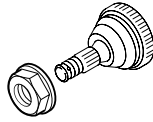

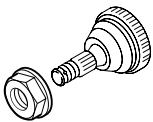
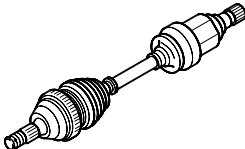

# CITROËN EVASION

## BVA - AL4

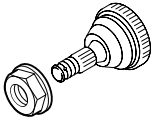
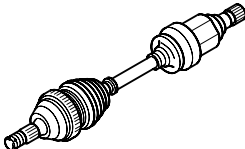

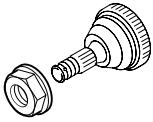
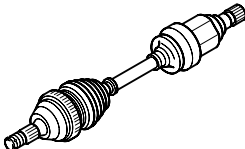









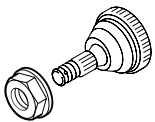
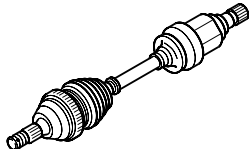





		G / D	Repère	Neuve	E.S.
(EW10J4) Ess 2 L 16 S	 3297 12 3297 13 3297 03 Ø 24 x 150 - H 13,5	G	8 LN 93	3272 2W	3272 3W
		D	8 MN 01	3273 8Z	3273 9A

# CITROËN C15











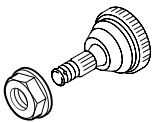
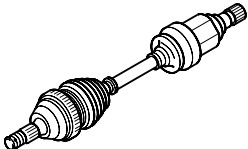

<b>BV - BH3</b>						
			<b>G/D</b>	<b>Repère</b>	<b>Neuve</b>	<b>E.S.</b>
(XV8-XW7-XY7) Ess 1 L - 1,1 L - 1,4 L → 09/87	 <b>3297 14</b> Ø 20 x 150 - H 18		<b>G/D</b>		-	<b>3274 C4</b>
<b>BV - MA</b>						
			<b>G/D</b>	<b>Repère</b>	<b>Neuve</b>	<b>E.S.</b>
(TU9-TU1-TU3) Ess 1 L - 1,1 L - 1,4 L 05/88 →	 <b>3297 14</b> Ø 20 x 150 - H 18		<b>G</b>		<b>3272 R3</b>	<b>3272 3K</b>
			<b>D</b>		<b>3273 X8</b>	<b>3273 5P</b>
<b>BV - BE1 - BE3</b>						
			<b>G/D</b>	<b>Repère</b>	<b>Neuve</b>	<b>E.S.</b>
(E1A-G1A) Ess 1,118 L - 1,294 L	 <b>3297 14</b> Ø 20 x 150 - H 18		<b>G</b>	8 HN 09 8 HN 11 8 HN 57	<b>3272 R5</b>	<b>3272 5K</b>
			<b>D</b>	8 HN 10 8 HN 12 8 JN 58	<b>3273 Y0</b>	<b>3273 5R</b>
(XUD7) DI 1,8 L	 <b>3297 14</b> Ø 20 x 150 - H 18		<b>G</b>	8 HN 09 8 HN 11 8 HN 57	<b>3272 R5</b>	<b>3272 5K</b> → 05/95 <b>3272 4K</b> 05/95 →
			<b>D</b>	8 HN 10 8 HN 12 8 JN 58	<b>3273 Y0</b>	<b>3273 5R</b> → 05/95 <b>3273 5Q</b> 05/95 →
(DW8B) DI 1,9 L	 <b>3297 14</b> Ø 20 x 150 - H 18		<b>G</b>	8 HN 09 8 HN 11 8 HN 57	<b>3272 R5</b>	<b>3272 4K</b>
			<b>D</b>	8 HN 10 8 HN 12 8 JN 58	<b>3273 Y0</b>	<b>3273 5Q</b>



# CITROËN BERLINGO (VP-VU)

<b>BV - MA</b>					
		G D	Repère	Neuve	E.S.
VU	 <b>3297 14</b>	G		<b>3272 9G</b>	<b>3272 5L</b>
(TU1M-TU3.2-TU3JP) Ess 1,1 L - 1,4 L → 07/99	  Ø 20 x 150 - H 18	D		3273 0V RP <b>3273 4T</b> → 02/97	<b>3273 6A</b> → 02/97
				3273 2Q RP <b>3273 4T</b> 02/97 →	<b>3273 6C</b> 02/97 →
VU	 <b>3297 00</b> <b>3297 02</b> <b>3297 03</b> Ø 24 x 150 - H 13,5	G		<b>3272 9G</b>	<b>3272 7L</b>
(TU1M-TU1JP-TU3.2-TU3JP) Ess 1,1 L - 1,4 L 07/99 →		D		<b>3273 4T</b>	<b>3273 6G</b>
VU	 <b>3297 00</b> <b>3297 02</b> <b>3297 03</b> Ø 24 x 150 - H 13,5	G		3272 Z2 RP <b>3272 6F</b>	<b>3272 6L</b>
→ 11/98		D		<b>3273 1C</b> → 02/97	<b>3273 6E</b> → 02/97
(TU1M-TU3.2-TU3JP) Ess 1,1 L - 1,4 L		G		<b>3273 2P</b> 02/97 →	<b>3273 6F</b> 02/97 →
11/98 →		D		<b>3272 6F</b>	<b>3272 8L</b>
VP	 <b>3297 07</b> Ø 24 x 150 - H 20,2	G		<b>3272 9G</b>	<b>3272 5L</b>
(TU1M-TU1JP-TU3.2-TU3JP) Ess 1,1 L - 1,4 L → 07/99		D		3273 2Q RP <b>3273 4T</b>	<b>3273 6C</b>
VP	 <b>3297 00</b> <b>3297 02</b> <b>3297 03</b> Ø 24 x 150 - H 13,5	G		<b>3272 9G</b>	<b>3272 7L</b>
(TU1M-TU1JP-TU3.2-TU3JP) Ess 1,1 L - 1,4 L 07/99 →		D		<b>3273 4T</b>	<b>3273 6G</b>
VP	 <b>3297 00</b> <b>3297 02</b> <b>3297 03</b> Ø 20 x 150 - H 18	G		3272 Z2 RP <b>3272 6F</b>	<b>3272 6L</b>
→ 11/98		D		<b>3273 2P</b>	<b>3273 6F</b>
(TU3JP) Ess 1,4 L		G		<b>3272 6F</b>	<b>3272 8L</b>
11/98 →		D		<b>3273 3Z</b>	<b>3273 6H</b>

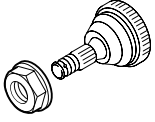
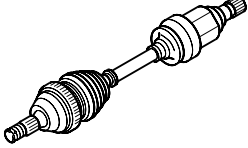
# CITROËN BERLINGO (VP-VU)







						
<b>BV - BE3 - BE4 - BE5</b>						
(XU7JB) Ess 1,8 L		 <b>3297 12</b> <b>3297 13</b> <b>3297 03</b> Ø 24 x 150	<b>G</b>	8 KN 71 8 KN 77	<b>3272 Y3</b>	<b>3272 9L</b>
(XUD7-XUD9-DW8) DI Atmo 1,8 L - 1,9 L			<b>D</b>	8 KN 73 8 KN 79	<b>3273 0R</b>	<b>3273 6J</b>
(XU7JB) Ess 1,8 L		 <b>3297 12</b> <b>3297 13</b> <b>3297 03</b> Ø 24 x 150	<b>G</b>	8 KN 71 8 KN 77	<b>3272 Y3</b> → 02/2000	<b>3272 1N</b> → 02/200
				8 KN 97	<b>3272 6W</b> 02/2000 →	<b>3272 7W</b> 02/2000 →
			<b>D</b>	8 KN 73 8 KN 79	<b>3273 0R</b> → 02/2000	<b>3273 6K</b> → 02/2000
				8 LN 98	<b>3273 9Z</b> 02/2000 →	<b>3273 AA</b> 02/2000 →
(XUD7-XUD9-DW8) DI Atmo 1,8 L - 1,9 L		 <b>3297 12</b> <b>3297 13</b> <b>3297 03</b> Ø 24 x 150	<b>G</b>	8 KN 71 8 KN 77	<b>3272 Y3</b>	<b>3272 1N</b>
			<b>D</b>	8 KN 73 8 KN 79	<b>3273 0R</b>	<b>3273 6K</b>
(DW10TD) DI Turbo 2 L HDi		 <b>3297 12</b> <b>3297 13</b> <b>3297 03</b> Ø 24 x 150	<b>G</b>	8 KN 72 8 KN 78	<b>3272 Z7</b>	<b>3272 7S</b>
			<b>D</b>	8 KN 73 8 KN 79	<b>3273 0R</b>	<b>3273 6J</b>
			<b>G</b>	8 KN 72 8 KN 78	<b>3272 Z7</b>	<b>3272 8S</b>
			<b>D</b>	8 KN 73 8 KN 79	<b>3273 0R</b>	<b>3273 6K</b>
<b>BV - SA13</b>						
		 <b>3297 07</b> Ø 24 x 150 - H 20,2	<b>G</b>		<b>3272 0Q</b>	-
			<b>D</b>		<b>3273 1S</b>	-

VU (véhicule utilitaire) : - Commercial vehicle - Vehículo utilitario - Veículo utilitário - Nutzfahrzeug - Veicoli commerciali - bedrijfsauto

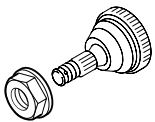
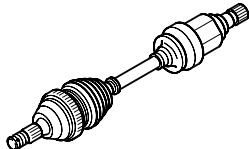

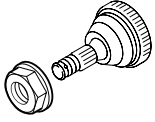
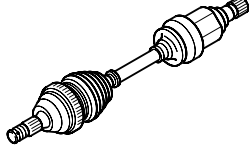

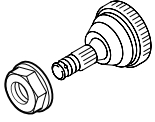
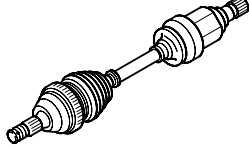
VP (véhicule particulier) : - Passenger vehicle - Vehículo particular - Veículo particular - PKW - Autovetture - personenauto

⚡ Electrique : Elctric - Elctrico - Elctrico - Elektrisch - Elettrico - Electric



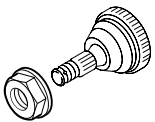
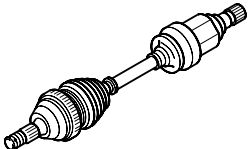

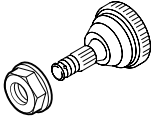
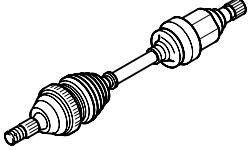

# CITROËN JUMPY

<b>BV - BE3 BE3R - BE4R</b>						
		G	D	Repère	Neuve	E.S.
(1580 SPI) <b>Ess 1,6 L</b> (XU7JP-EW10J4) <b>Ess 1,8 L - 2 L 16 S</b> (XUD9A-DW8) <b>DI Atmo 1,9 L</b>	 <b>3297 12</b> <b>3297 13</b> <b>3297 03</b> <small>Ø 24 x 150</small>	G		8 JN 69	<b>3272 L1</b>	<b>3272 1L</b>
				8 JN 71		
			8 KN 21			
			8 KN 23			
		D		8 JN 61	<b>3273 V7</b>	<b>3273 5X</b>
				8 JN 70		
				8 JN 72		
				8 KN 22		
				8 KN 24		
<b>BV - ME</b>						
		G	D	Repère	Neuve	E.S.
(XUD9TE) <b>DI Turbo 1,9 L</b>	 <b>3297 12</b> <b>3297 13</b> <b>3297 03</b> <small>Ø 24 x 150</small>	G		8 JN 53	<b>3272 V0</b>	<b>3272 2L</b>
				8 JN 55		
			8 KN 85			
			8 KN 87			
		D		8 JN 54	<b>3273 06</b>	<b>3273 5Y</b>
				8 JN 56		
				8 KN 86		
				8 KN 88		
<b>BV - ML5T</b>						
		G	D	Repère	Neuve	E.S.
(XUD9TE) <b>DI Turbo 1,9 L</b>	 <b>3297 12</b> <b>3297 13</b> <b>3297 03</b> <small>Ø 24 x 150</small>	G		8 JN 53	<b>3272 V0</b>	<b>3272 2L</b>
				8 JN 55		→ 09/96
				8 KN 85		<b>3272 3L</b>
				8 KN 87		09/96 →
		D		8 JN 54	<b>3273 06</b>	<b>3273 5Y</b>
				8 JN 56		→ 09/96
				8 KN 86		<b>3273 7E</b>
				8 KN 88		09/96 →
(DW10ATED-DW10BTED) <b>DI Turbo 2 L HDi</b> (DW10ATED4) <b>DI Turbo 2 L HDi 16 S</b>	 <b>3297 12</b> <b>3297 13</b> <b>3297 03</b> <small>Ø 24 x 150</small>	G		8 LN 42	<b>3272 9C</b>	<b>3272 4L</b>
				8 LN 44		
		D		8 LN 41	<b>3273 3Q</b>	<b>3273 5Z</b>
				8 LN 43		

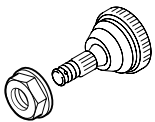
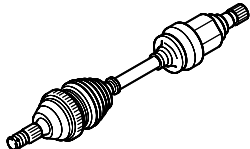

# CITROËN JUMPER → 02/2002

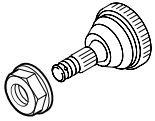
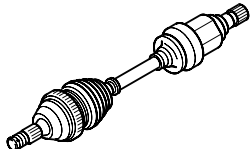
<b>BV - ME5T BV - ML5T - MLUC</b>			<b>G/D</b>	<b>Repère</b>	<b>Neuve</b>	<b>E.S.</b>
(XU10J2) <b>Ess 2 L</b>	 <b>3318 17</b>		<b>G</b>	8 JN 12	<b>3272 J0</b> → 04/2001	<b>3272 6K</b> → 04/2001
(XUD9AU) <b>DI Atmo 1,9 L</b>				8 JN 18		
(XUD9UTF-DJ5) <b>DI Turbo 1,9 L - Atmo 2,5 L</b>			<b>D</b>	8 JN 73	<b>3273 Q5</b> RP <b>3273 CH</b>	<b>3273 5S</b> → 04/2000
(DW10TD) <b>DI Turbo 2 L HDi</b> <b>4x4 (Transmission AV)</b>	8 JN 19	<b>3273 CJ</b> 04/2000 →				
<b>4x4 (Transmission AR)</b>	 <b>3318 18</b> Ø 33 x 150		<b>G/D</b>		<b>3274 C1</b>	-
<b>BV - MG5T BV - MLGU</b>			<b>G/D</b>	<b>Repère</b>	<b>Neuve</b>	<b>E.S.</b>
	 <b>3318 17</b>		<b>G</b>	8 JN 14	<b>3272 J1</b> → 04/2001	<b>3272 7K</b> → 04/2001
				8 JN 20		
<b>1000 Kg - 1400 Kg</b>			<b>D</b>			<b>3273 CK</b>
(XU10J2) <b>Ess 2 L</b>	<b>3318 18</b>					
(DJ5) <b>DI Atmo 2,5 L</b>			8 JN 16			
(DJ5TED) <b>DI Turbo 2,5 L</b>	<b>D</b>			8 KN 56	<b>3273 Q7</b> → 12/95	<b>3273 5V</b> → 12/95
(SOFIM) <b>DI 2,8 L HDi</b> <b>4x4 (Transmission AV)</b>				8 KN 58		
	<b>G</b>			8 JN 11	<b>3272 CN</b> 12/95 →	<b>3272 9K</b> 12/95 →
				8 JN 17		
	<b>D</b>			8 KN 57	<b>3273 CN</b> 12/95 →	<b>3273 5W</b> 12/95 →
				8 KN 59		
	<b>G/D</b>			8 KN 89	<b>3274 C1</b>	-
				8 KN 91		
	<b>D</b>			8 KN 90	<b>3274 C1</b>	-
				8 KN 92		
<b>4x4 (Transmission AR)</b>	 <b>3318 18</b> Ø 33 x 150		<b>G/D</b>		<b>3274 C1</b>	-

# CITROËN JUMPER 02/2002 →

<b>BV - ML</b>						
		G D	Repère	Neuve	E.S.	
(DW10TD) DI Turbo 2 L HDi	(MLUC)	 <b>3318 17</b>	G	<b>3272 CH</b>	-	
		Ø 28 x 150 - H 17,5	D	<b>3273 CH</b>	-	
(XU10J2) Ess 2 L 1000 Kg - 1400 Kg	(MLGU)	 <b>3318 17</b>	G	<b>3272 CK</b>	-	
		Ø 28 x 150 - H 17,5	D	<b>3273 CK</b>	-	
(DW12TED) DI Turbo 2,2 L HDi (SOFIM) DI 2,8 L HDi	1800 Kg	 <b>3318 18</b>	G	<b>3272 CN</b>	-	
		Ø 33 x 150	D	<b>3273 CN</b>	-	
<b>BVA - 4HP20</b>						
		G D	Repère	Neuve	E.S.	
(SOFIM) DI 2,8 L HDi	1000 Kg - 1400 Kg	 <b>3318 17</b>	G	8 MN 31	<b>3272 AK</b>	-
		Ø 28 x 150 - H 17,5	D	8 MN 30	<b>3273 AP</b>	-
	1800 KG	 <b>3318 18</b>	G	8 MN 27	<b>3272 AN</b>	-
		Ø 33 x 150	D	8 MN 26	<b>3273 AR</b>	-

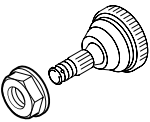
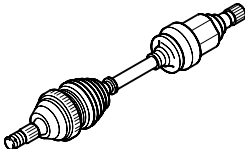
## CITROËN C25

					
		<b>G</b> / <b>D</b>	<b>Repère</b>	<b>Neuve</b>	<b>E.S.</b>
TT Sauf DI 1,9 L	 <b>3318 17</b> Ø 28 x 150 - H 17,5	<b>G</b>	8 GN 29 8 JN 24	<b>3272 85</b>	<b>3272 7N</b>
		<b>D</b>	8 GN 13 8 JN 25	<b>3273 H1</b>	<b>3273 6R</b>
(XUD9) DI 1,9 L	 <b>3318 17</b> Ø 28 x 150 - H 17,5	<b>G</b>	8 GN 29 8 JN 24	<b>3272 85</b>	<b>3272 7N</b>
		<b>D</b>	8 GN 15 8 JN 27	<b>3273 H2</b>	<b>3273 6S</b>

## ENTRAINEURS CITROËN C25

TT → 09/90	Entraîneur avec rotules	<b>G</b>		95 576 557 <b>NFP</b>	95 606 910 <b>NFP</b>
		<b>D</b>		95 569 340 <b>NFP</b>	95 606 911 <b>NFP</b>

# A - LN - LNA - VISA - GS - GSA

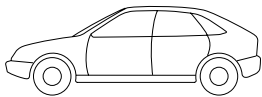
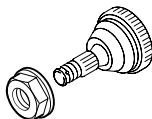
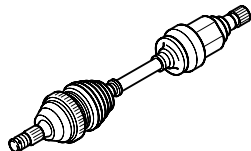



					
			G / D	Neuve	E.S.
<b>A Tous Types</b> (Transmission à billes)		5 420 543 NFP Ø 22 x 150 - H 19,25	Roue	NFP	3274 C2 *
			BV	NFP	
<b>LN 0,602 L - LNA 0,652</b>			Roue	NFP	3274 C3 * NFP
			BV	NFP	
<b>Visa 0,652 L</b>		3297 14 Ø 28 x 150 - H 16,5	G / D	3274 A9 NFP	95 582 400
<b>LNA 1,124 L</b> <b>Visa 0,954 L - 1,124 L - 1,219 L - 1,360 L</b>			G / D	3274 53 NFP	95 582 409 RP 3274 C4
<b>Visa GTi - Diesel</b>			G	3272 R5	95 619 481 RP 3272 5K
			D	3273 Y0	95 619 482 RP 3273 5R
<b>GS → 10/78</b>		5 420 543 NFP Ø 22 x 150 - H 19,25	G / D	NFP	95 582 415 NFP
<b>GS 11/78 →</b>					
<b>GSA</b>			5 420 543 NFP → 03/81 Ø 22 x 150 - H 19,25	G / D	NFP
		3297 00 03/81 → Ø 24 x 150 - H 13,5			

Transmission à billes : Ball-type driveshaft - Transmisión a bola - Transmissão de esferas - Kugel gelenkwelle - Trasmissione a sfera - Kogelkoppeling

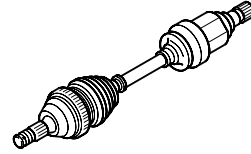
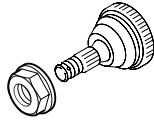
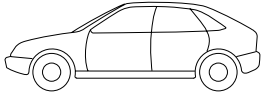
\* Transmissions côté roue + côté boîte de vitesse : Driveshafts wheel side + gearbox side - Trasmisiones lado rueda + lado caja de velocidades - Transmissão lado roda + lado caixa de velocidades - Gelenkwellen, rad- und getriebeseite - Trasmissioni lato ruota + lato scatola cambio - Aandrijfassen, wielzijde + versn.bakzijde



# CX



		G / D	Neuve	E.S.
(Voie élargie) <b>Tous Types BV4 07/80 →</b> <b>Tous Types BV5</b> <b>Reflex et Athena BV4 07/80 →</b>	<b>3297 00</b> 06/76 → Ø 24 x 150 - H 13,5	G	NFP	95 618 339  95 618 341 
		D	NFP	95 618 340  95 618 342 
		G	NFP	95 618 343 <b>NFP</b>
		D	NFP	95 618 344 <b>NFP</b>
<b>Tous Types BV Auto</b>				

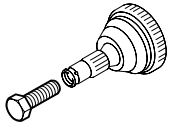
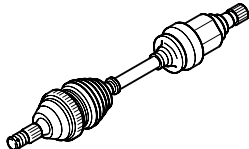

# CITROËN C35

					
		G / D	Repère	Neuve	E.S.
<b>TT</b> (Sans entraîneur)	 <b>6922 14</b>	G / D		<b>NFP</b>	<b>95 582 438</b>
<b>TT</b> (Entraîneur + Rotules)		G / D		<b>NFP</b>	<b>95 582 439</b> <b>NFP</b>
<b>TT</b> (Avec entraîneur)		G / D		<b>NFP</b>	<b>95 582 440</b>

HM8 x 125 - H 45



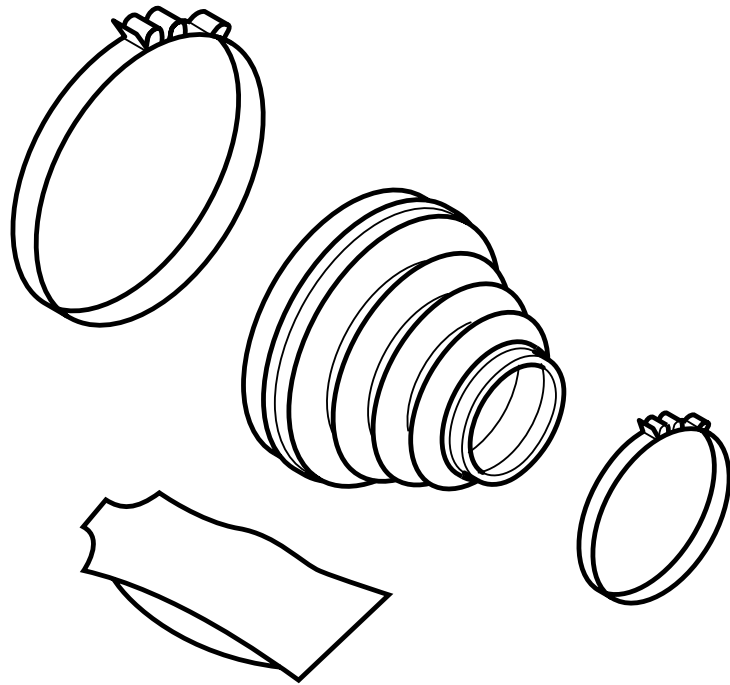

**Sans entraîneur** : Without drive - Con arrastrador - Com caixa de comando - Mit mitnehmer - Con trascinatore - Met koppelstuk

**Avec entraîneur** : With drive - Sin arrastrador - Sem caixa de comando - Ohne mitnehmer - Senza trascinatore - Zonder koppelstuk

**Entraîneur + rotules** : Drive + ball joints - Arrastrador + rotulas - Caixa de comando + rótulas - Mitnehmer + kugelgelenk - Trascinatore + rotule - Koppelstuk + kogels

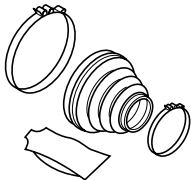

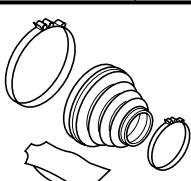
# CITROËN AX

<b>BV - MA</b>				
				G/D
(TU9-TU1) <b>Ess 1 L - 1,1 L Carbu</b> → 02/91 <b>4x4</b> (Transmission AV)	G/D	3293 81	3287 69	
(TUD5) <b>DI 1,5 L</b>				
(TU9-TU1) <b>Ess 1 L - 1,1 L Carbu</b> 02/91 → (TU1M) <b>1,1 L IE Mono</b> (TU3) <b>Ess 1,4 L</b> → 04/91 Sauf <b>TU3FJ-TU3J2</b>			3287 75	
(TUD3) <b>DI 1,4 L</b> → 04/91 (TU2.4) <b>Sport</b>				
(TU3) <b>Ess 1,4 L</b> 04/91 → Sauf <b>TU3FJ-TU3J2</b> (TUD3) <b>DI 1,4 L</b> 04/91 →			3287 69	
(TU3FJ) <b>Ess 1,4 L</b>		G/D	3293 77	
(TU3FJ) <b>Ess 1,4 L</b> 03/93 →		G/D	3293 77 (* 96 024 490 80)	3287 69 (avec gorge sur arbre)
			3293 05 (* 244 886 1)	3287 83 (sans gorge sur arbre)
(TU3J2) <b>Ess 1,4 L</b>		G/D	3293 81	3287 69
<b>4x4</b> (Transmission AR)		G/D	3293 81	95 661 714 (Ø 69)
<b>BV - SA13</b>				
				G/D
		G/D	3293 81	3287 69

Sauf : Exept - Salvo - Salvo - Ausser - Salvo - Behalve

Transmission AV : Front driveshaft - Transmision delantera - Transmissão da frente - Vordere gelenkwelle - Trasmissione anteriore - Aandrijf-as voor

Transmission AR : Rear driveshaft - Transmision trasera - Transmissão de trás - Hintere gelenkwelle - Trasmissione posteriore - Aandrijf-as achter



\* Inscription : Inscription - Inscripción - Inscrição - Aufschrift - Iscrizione - Merketen

Avec gorge sur arbre : With groove on shaft - Con ranura sobre arbol - Com gola no véio - Mit rille an welle - Con scanalature sull'albero - Met groef op de as

Sans gorge sur arbre : Without groove on shaft - Sin ranura sobre arbol - Sem gola no véio - Ohne rille an welle - Senza scanalature sull'albero - Zonder groef op de as

 Electrique : Elctric - Elctrico - Elctrico - Elektrisch - Elettrico - Electric

# CITROËN SAXO

<b>BV - MA</b>			
		Côté Roue	Côté BV
(TU9-TU1-TU1M+) <b>Ess 1 L - 1,1 L</b> → 08/99 (Roue fixation 3 trous)	<b>G</b>	<b>3293 08</b> (Ø 20,8) (* 144 839 0)	<b>3287 75</b>
	<b>D</b>	<b>3293 11</b> (Ø 24) (* 144 840 0)	
(TU9-TU1M+-TU1JP) <b>Ess 1 L - 1,1 L</b> (TU3.2-TU3JP) <b>Ess 1,4 L</b> (TUD5) <b>DI 1,5 L</b> (Roue fixation 4 trous)	<b>G</b>	<b>3293 12</b> (Ø 23,7) (* 144 840 0)	<b>3287 69</b>
	<b>D</b>	<b>3293 13</b> (Ø 30) (* 144 841 1)	
(TU5JP-TU5J4) <b>Ess 1,6 L - 1,6 L 16 S</b>	<b>G/D</b>	<b>3293 05</b> (* 244 886 1)	<b>3287 83</b>
<b>BVA - MB3</b>			
		Côté Roue	Côté BV
(TU3JP-TU5JP) <b>Ess 1,4 L - 1,6 L</b> → 01/98	<b>G</b>	<b>3293 04</b> (* INEP 41 67)	<b>3287 89</b>
	<b>D</b>		<b>3287 83</b>
(TU3JP-TU5JP) <b>Ess 1,4 L - 1,6 L</b> 01/98 →	<b>G</b>	<b>3293 19</b> (* 3 402 090)	<b>3287 89</b>
	<b>D</b>		<b>3287 83</b>
<b>BV - SA13</b>			
		Côté Roue	Côté BV
<b>⚡</b>	<b>G/D</b>	<b>3293 12</b>	<b>3287 83</b>

**Roue fixation 3 trous** : Wheel with 3 bolt fixings - Disco de rueda con fijacion 3 taladros - Roda 3 parafusos - 3 Loch felge - Ruota fissaggio 3 fori - Wiel bevestiging 3 gaten  
**Roue fixation 4 trous** : Wheel with 4 bolt fixings - Disco de rueda con fijacion 4 taladros - Roda 4 parafusos - 4 Loch felge - Ruota fissaggio 4 fori - Wiel bevestiging 4 gaten  
**Administration** : Fleet - Administracion - Administração - Dehorde - Flottes - Wagenpark Franse overheid (niet voor benelux)



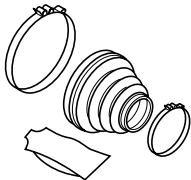
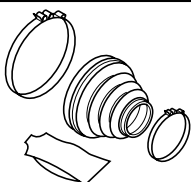
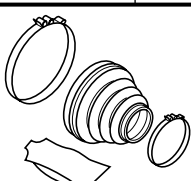

\* **Inscription** : Inscription - Inscripción - Inscrição - Aufschrift - Iscrizione - Merketen

**⚡ Electrique** : Elctric - Elctrico - Elctrico - Elektrisch - Elettrico - Electrisch

# CITROËN C3

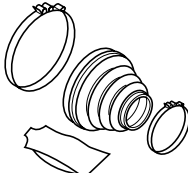
<b>CITROËN C3</b>			
<b>BV - MA</b>			
	<b>G</b> / <b>D</b>	<b>Côté Roue</b>	<b>Côté BV</b>
(TU1JP-TU3JP) <b>Ess 1,1 L - 1,4 L</b>	<b>G</b>	<b>3293 A3</b>	<b>3287 94</b>
(DV4TD) <b>DI Turbo 1,4 L</b>	<b>D</b>	<b>3293 35</b>	<b>3287 93</b>
(TU5JP4) <b>Ess 1,6 L 16S</b>	<b>G</b>	<b>3293 A5</b>	<b>3287 94</b>
	<b>D</b>	<b>3293 A4</b>	<b>3287 93</b>
<b>BV - BE4R</b>			
	<b>G</b> / <b>D</b>	<b>Côté Roue</b>	<b>Côté BV</b>
(DV4TED4) <b>DI Turbo 1,4 L 16S</b>	<b>G</b>	<b>3293 A5</b>	<b>3287 95</b>
	<b>D</b>	<b>3293 20</b>	<b>3287 88</b>
<b>BVA - AL4</b>			
	<b>G</b> / <b>D</b>	<b>Côté Roue</b>	<b>Côté BV</b>
(TU3JP) <b>Ess 1,4 L</b>	<b>G</b>	<b>3293 A3</b>	<b>3287 94</b>
	<b>D</b>	<b>3293 35</b>	<b>3287 93</b>

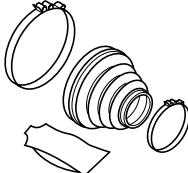
# CITROËN ZX

<b>CITROËN ZX</b>				
<b>BV - MA</b>				
		<b>G/D</b>	<b>Côté Roue</b>	<b>Côté BV</b>
(TU9-TU1-TU1M+) <b>Ess 1,1 L</b> (TU3.2-TU3JP-TU3M-TU3MC)		<b>G/D</b>	<b>3293 77</b> → 04/95	<b>3287 69</b> → 04/95
<b>Ess 1,4 L</b> (TUD3-TUD5) <b>DI Atmo 1,4 L - 1,5 L</b>		<b>G/D</b>	<b>3293 05</b> 04/95 →	<b>3287 83</b> 04/95 →
(TU3M-TU3MC) <b>Ess 1,4 L IE Mono</b>		<b>G/D</b>	<b>3293 91</b> (3 plis) (* 95 631 464 80 96 044 510 80 96 135 591 80)	<b>3287 69</b>
			<b>3293 96</b> (6 plis) (* 96 151 289 80 96 172 452 80)	
<b>BV - BE3/5 BVA - 4HP14</b>				
		<b>G/D</b>	<b>Côté Roue</b>	<b>Côté BV</b>
(XU5M-XU5JP-XU7JP-XU7JP4) <b>Ess 1,6 L - 1,8 L - 1,8 L 16 S</b>		<b>G/D</b>	<b>3293 83</b> (* 96 009 166 80)	<b>3293 59</b> (* 95 025 088 80)
			<b>3293 96</b> (* 96 151 289 80 96 172 452 80)	<b>3287 79</b> (* 96 098 023 80 96 210 475 80)
(XU9JA-XU9JAZ) <b>Ess 1,9 L</b>		<b>G/D</b>	<b>3293 91</b> (* 95 631 464 80 96 044 510 80 96 135 591 80)	<b>3293 59</b> (* 95 025 088 80)
			<b>3293 96</b> (* 95 151 289 80 96 172 452 80)	<b>3287 79</b> (* 96 098 023 80 96 210 475 80)

3 plis : 3 corrugations - 3 pliegues - 3 pregas - 3 falten - 3 pieghe - 3 plooiën

6 plis : 6 corrugations - 6 pliegues - 6 pregas - 6 falten - 6 pieghe - 6 plooiën

\* Inscription : Inscription - Inscripción - Inscrição - Aufschrift - Iscrizione - Merketen



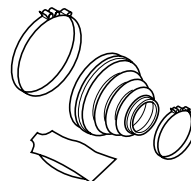

# CITROËN ZX

**BV - BE3/5**  
**BVA - 4HP14**

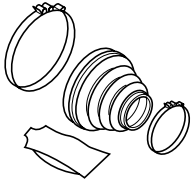

		G	D	Côté Roue	Côté BV
(XU5M-XU5JP-XU7JP) <b>Ess 1,6 L - 1,8 L</b> (XU9JA-XU9JAZ) <b>Ess 1,9 L</b> (XU10J2) <b>Ess 2 L TT sauf 16 S</b> (XUD7-XUD9) <b>DI Atmo 1,8 L - 1,9 L</b> (XUD9TE) <b>DI Turbo 1,9 L</b>	  	G/D		<b>3293 91</b> (* 95 631 464 80 96 044 510 80 96 135 591 80)	<b>3293 59</b> (* 95 025 088 80)
				<b>3293 96</b> (Ø 17,5) → 08/96 (* 95 151 289 80 96 172 452 80)	<b>3287 79</b> → 08/96 (* 96 098 023 80 96 210 475 80)
				<b>3293 03</b> (Ø 17,5) 08/96 → (* 96 214 349 80)	<b>3287 81</b> 08/96 → (* 95 209 940 80)
(XU10J4) <b>Ess 2 L 16 S</b>	→ 08/96	G/D		<b>3293 91</b> (* 95 631 464 80 96 044 510 80 96 135 591 80)	<b>3293 59</b> (* 95 025 088 80)
				<b>3293 96</b> (Ø 17,5) (* 95 151 289 80 96 172 452 80)	<b>3287 79</b> (* 96 098 023 80 96 210 475 80)
(XU10J4-XU10J4RS) <b>Ess 2 L 16 S</b>	08/96 →			<b>3293 03</b> (* 96 214 349 80)	<b>3287 81</b> (* 96 209 940 80)
(XUD7-XUD9) <b>DI Atmo 1,8 L - 1,9 L</b>		G/D		<b>3293 83</b> (* 96 009 166 80)	<b>3293 59</b> (* 95 025 088 80)
				<b>3293 96</b> (* 96 151 289 80 96 172 452 80)	<b>3287 69</b> (Avec talon)
				<b>3293 77</b> (* 96 024 490 80)	<b>3287 74</b> (* 95 639 782 80)
				-	<b>3287 79</b> (* 96 098 023 80 96 210 475 80)

# CITROËN XSARA → 27/08/2000

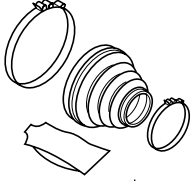
<b>BV - MA</b>				
		<b>G/D</b>	<b>Côté Roue</b>	<b>Côté BV</b>
(TU3JP) <b>Ess 1,4 L</b> → 01/99 (TU5JP) <b>Ess 1,6 L BL</b> → 03/98 / <b>BK</b> → 03/98 (TUD5) <b>DI 1,5 L BL</b> → 01/99 / <b>BK</b> → 03/98		<b>G/D</b>	<b>3293 05</b> (* 244 886 1)	<b>3287 69</b> Avec gorge d'accrochage <hr/> <b>3287 83</b> Sans gorge d'accrochage
(TU3JP)      01/99 → <b>Ess 1,4 L</b> (TU5JP) <b>BL</b> 03/98 → / <b>BK</b> 03/98 → <b>Ess 1,6 L</b> (TU5D) <b>BL</b> 03/98 → / <b>BK</b> 03/98 → <b>DI 1,5 L</b>		<b>G/D</b>	<b>3293 20</b>	<b>3287 88</b>
(TU3JP) <b>Ess 1,4 L</b> → 02/99 (TU5JP) <b>Ess 1,6 L</b> → 11/98 (TUD5) <b>DI 1,5 L</b> → 02/99		<b>G/D</b>	<b>3293 14</b> (* 2 152 02 2 0595 00)	<b>3287 74</b> (* 95 639 782 80)
(TU3JP) <b>Ess 1,4 L</b> 02/99 → (TU5JP) <b>Ess 1,6 L</b> 11/98 → (TU5D) <b>DI 1,5 L</b> 02/99 →		<b>G/D</b>	<b>3293 20</b>	<b>3287 88</b>
<b>BV - BE3</b> <b>BVA - AL4</b> <b>BVA - 4HP14</b>				
		<b>G/D</b>	<b>Côté Roue</b>	<b>Côté BV</b>
(TU5JP) <b>Ess 1,6 L</b> (XU7JB-XU7JP-XU7JP4) <b>Ess 1,8 L - 1,8 L 16 S</b> (XU10J4R-XU10J4RS) <b>Ess 2 L 16 S</b> (XUD7-XUD9-DW8) <b>Di 1,8 L - 1,9 L</b> (XUD9BSD-XUD9TE-DW10TD) <b>DI Turbo 1,9 L - 2 L HDi</b>		<b>G/D</b>	<b>3293 03</b> (* 96 214 349 80)	<b>3287 81</b> (* 96 209 940 80)

**Avec gorge d'accrochage** : With locating grooves - Con ranura de enganche - Com garganta de engate - Mit aufnehmerillen - Con scanalatura d'aggancio - Met verankeringgroeven  
**Sans gorge d'accrochage** : Without locating grooves - Sin ranura de enganche - Sem gola garganta de engate - Ohne aufnehmerillen - Senza scanalatura d'aggancio -  
 \* **Inscription** : Inscription - Inscricção - Inscricção - Aufschrift - Iscrizione - Merketen

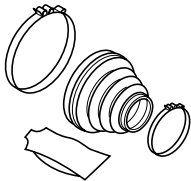
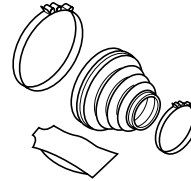

# CITROËN XSARA 28/08/2000 →

<b>BV - MA</b>		
G/D	Côté Roue	Côté BV
(TU3JP-TU5JP4) <b>Ess 1,4 L - 1,6 L 16 S</b>	<b>3293 20</b>	<b>3287 88</b>
<b>BV - BE4R BVA - AL4</b>		
G/D	Côté Roue	Côté BV
(TU5JP4-EW10J4-XU10J4RS) <b>Ess 1,6 L 16 S - 2 L 16 S</b> (DW10TD-DW10ATED) <b>DI Turbo 2 L HDi</b> Sans système ESP	<b>3293 03</b> (* 96 209 628 80)	<b>3287 81</b> (* 96 209 940 80)
(TU5JP4-EW10J4) <b>Ess 1,6 L 16 S - 2 L 16 S</b> (DW10ATED) <b>DI Turbo 2 L HDi</b> Avec système ESP	<b>3293 31</b> (* 96 459 674 80)	<b>3287 81</b> (* 96 209 940 80)
(DW8B) <b>DI Atmo 1,9 L</b>	<b>3293 03</b> (* 96 209 628 80)	<b>3287 81</b> (* 96 209 940 80)

# CITROËN XSARA PICASSO

## BV - BE4R

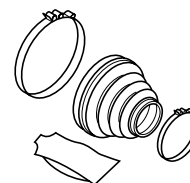

	G/D	Côté Roue	Côté BV
(TU5JP) <b>Ess 1,6 L</b> (EW7J4) <b>Ess 1,8 L 16 S</b>	G/D	<b>3293 03</b> (5 plis) → 01/2001 (* 96 214 349 80)	<b>3287 81</b> (* 96 209 940 8)
		<b>3293 31</b> (6 plis) 01/2001 → (* 96 390 323 80)	
(EW10J4) <b>Ess 2 L 16S</b> (DW10TD) <b>DI Turbo 2 L HDi</b>	G/D	<b>3293 03</b> (* 96 209 628 80)	<b>3287 81</b> (* 96 209 940 80)



  

	G/D	Côté Roue	Côté BV
(EW10J4) <b>Ess 2 L 16 S</b>	G/D	<b>3293 31</b> (* 96 459 674 80)	<b>3287 81</b> (* 96 209 940 80)

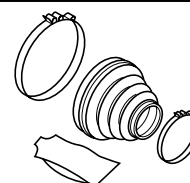

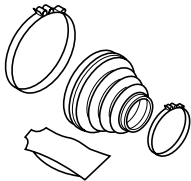
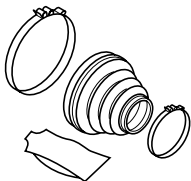
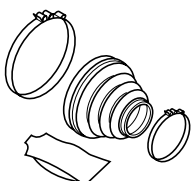

## BVA - AL4

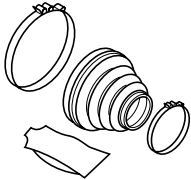

# CITROËN BX

<b>BV - BH3</b>			
		<b>Côté Roue</b>	<b>Côté BV</b>
(XY7) <b>Ess 1,1 L</b> → 05/88 (I), (GR) (XY7-TU3) <b>Ess 1,4 L</b> 05/88 →	<b>G</b> / <b>D</b>	<b>3293 51</b> (* 95 593 267 80)	<b>3287 61</b>
			<b>3287 74</b> (* 95 639 782 80)
<b>BV - MA</b>			
		<b>Côté Roue</b>	<b>Côté BV</b>
(TU1) <b>Ess 1,1 L</b> 05/88 → (I), (GR) (TU3-TU3F-TU3M-TU3FM) <b>Ess 1,1 L</b> 05/88 →	<b>G</b> / <b>D</b>	<b>3293 83</b> (* 96 009 166 80)	<b>3287 69</b>
	<b>G</b> / <b>D</b>	<b>3293 91</b> (* 95 631 464 80 96 044 510 80 96 135 591 80)	<b>3287 74</b> (* 95 639 782 80)
<b>BV - BE1 - BE3</b>			
		<b>Côté Roue</b>	<b>Côté BV</b>
(XU5-XU9) <b>Ess 1,6 L - 1,9 L</b> → 06/87		<b>G</b> / <b>D</b>	<b>3293 51</b> (* 95 593 267 80)
			<b>3293 59</b> (* 95 025 088 80) <b>3293 65</b> (* 95 549 621 80)
(XU5-XU9) <b>Ess 1,6 L - 1,9 L</b> 06/87 →		<b>G</b> / <b>D</b>	<b>3293 83</b> (* 96 009 166 80)
			<b>3293 59</b> (* 95 025 088 80) <b>3287 74</b> (* 95 639 782 80)

# CITROËN BX

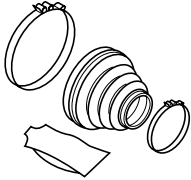
<b>BV - BE1 - BE3</b>			
			
	<b>G/D</b>	Côté Roue	Côté BV
(XUD7-XUD9) DI Atmo 1,7 L - 1,9 L		<b>3293 51</b> → 03/84 (* 95 593 267 80)	<b>3293 59</b> (* 95 025 088 80)
		<b>3293 65</b> → 06/87 (* 95 549 621 80)	
		<b>3293 83</b> 07/87 → (* 96 009 166 80)	<b>3293 59</b> (* 95 025 088 80)
DI Turbo  TT 	→ 01/93	<b>3293 91</b> (* 95 631 464 80 96 044 510 80 96 135 591 80)	<b>3293 59</b> (* 95 025 088 80)
	01/93 →	<b>3293 96</b> (* 96 151 289 80 96 172 452 80)	<b>3287 79</b> (* 96 098 023 80 96 210 475 80)
<b>BV - BE3 - 4X4</b>			
			
	<b>G/D</b>	Côté Roue	Côté BV
(Transmission AV) Ess - DI 1,9 L 4x4	<b>G/D</b>	<b>3293 91</b> (* 95 631 464 80 96 044 510 80 96 135 591 80)	<b>3293 59</b> (* 95 025 088 80)
(Transmission AR) Ess - DI 1,9 L 4x4 → 06/93	<b>G/D</b>	<b>3293 85</b> (* 96 008 270 80)	<b>3293 59</b> (* 95 025 088 80)
(Transmission AR) Ess - DI 1,9 L 4x4 06/93 →	<b>G/D</b>	<b>3293 76</b>	<b>3293 76</b>

# CITROËN XANTIA

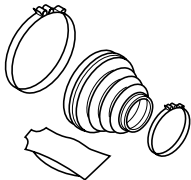
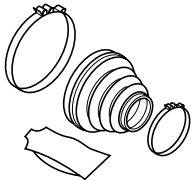
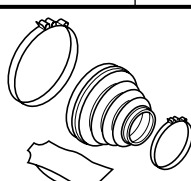
<b>BV - BE3 BVA - 4HP14</b>				G/D	
				Côté Roue	Côté BV
TT • Arbres pleins Ø 26 Sans hydractive	→ 05/95	G/D	<b>3293 96</b> (* 96 151 289 80 96 172 452 80)	<b>3287 79</b> (* 96 098 023 80 96 210 475 80)	
			<b>3293 83</b> (* 96 009 166 80)		
TT •• Arbres tubulaires Ø 40 Sans hydractive	05/95 →	G/D	<b>3293 03</b> (* 96 214 349 80)	<b>3287 81</b> (* 96 209 940 80)	
(XU10J4R) Ess 2 L 16 S Suspension hydractive	05/95 →	G	<b>3293 96</b> (* 96 172 452 80)	<b>3287 79</b> (* 96 209 941 80)	
		D	<b>3293 03</b> (* 96 214 349 80)	<b>3287 81</b> (* 96 209 940 80)	
<b>BV - ML5T</b>				G/D	
(XU10J2TE-ES9J4) Ess 2 L Turbo - V6 3 L (XUD11BTE) DI Turbo 2,1 L      Sans suspension hydractive (DW10ATED) DI Turbo 2 L HDi		G/D	<b>3293 02</b> (* 96 211 576 80)	<b>3287 80</b> (* 96 209 941 80)	
			(XU10J2TE-ES9J4) Ess 2 L Turbo - V6 3 L (XUD11BTE) DI Turbo 2,1 L      suspension hydractive (DW10ATED) DI Turbo 2 L HDi	G	<b>3293 98</b> RP <b>3293 A1</b> (* 14 765 260 80)
		D	<b>3293 02</b> (* 96 211 576 80)	<b>3287 80</b> (* 96 209 941 80)	
<b>BVA - 4HP20</b>				G/D	
(ES9J4) Ess V6 3L		G/D	<b>3293 02</b> (* 96 211 576 80)	<b>3287 80</b> (* 96 209 941 80)	

• Arbres pleins : Solid shafts - Veios cheios - Veios maciços - Antriebswellen massiv - Alberi pieni - Massieve assen

•• Arbres tubulaires : Hollow shafts - Veios tubulares - Veios tubulares - Antriebswellen hohl - Alberi tubolari - buisvorviige assen

Sans suspension hydractive : Without suspension hydractive - Sin suspension hydractiva - Sem suspensão hidractiva - Ohne hydractiv federung - Senza sosensione dell'idrattiva - Zonder vering hydractief

Avec suspension hydractive : With suspension hydractive - Con suspension hydractiva - Con suspensão hidractiva - Mit hydractiv federung - Con sosensione dell'idrattiva - Met vering hydractief

\* Inscription : Inscription - Inscricion - Inscricção - Aufschrift - Iscrizione - Merketen

# CITROËN XANTIA

## BVA - AL4

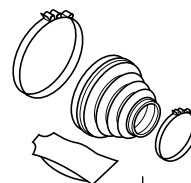

(XU7JP4-XU10J4R) <b>Ess 1,8 L 16 S - 2 L 16</b> (XUD9TE) <b>DI Turbo 1,9 L</b>	G	<b>Côté Roue</b>	<b>Côté BV</b>
	D	<b>3293 03</b> (* 96 214 349 80)	<b>3287 81</b> (* 96 209 940 80)

# CITROËN C5

<b>BV - BE4R BVA - AL4</b>			
	G / D	Côté Roue	Côté BV
(EW7J4-EW10D-EW10J4) <b>Ess 1,8 L 16S - 2 L - 2 L 16 S</b> (DW10TD-DW10ATED) <b>DI Turbo 2 L HDi</b>	G / D	<b>3293 03</b> (* 96 214 349 80)	<b>3287 81</b> (* 96 209 940 80)
<b>BV - ML5T BVA - 4HP20</b>			
	G / D	Côté Roue	Côté BV
(ES9J4S) <b>Ess V6 3L</b> (DW12TED4) <b>DI Turbo 2,2 L HDi 16S</b>	G / D	<b>3293 02</b> → 04/2001 (* 96 209 626 80)	<b>3287 91</b> (* 96 381 149 80)
(DW10ATED) <b>DI Turbo 2 L HDi</b>	G / D	<b>3293 34</b> 04/2001 →	<b>3287 80</b> → 04/2001 (* 96 209 941 80)
	G / D	<b>3293 02</b> → 04/2001 (* 96 209 626 80)	<b>3287 91</b> 04/2001 → (* 96 381 149 80)

# CITROËN XM

## BV - BE3 - BE5

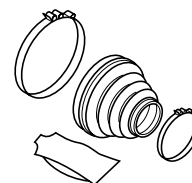

	G/D	Côté Roue	Côté BV
(XU10M-XU102C-XU10J2) <b>Ess 2 L</b> → 07/94 (XUD11A) <b>DI Atmo 2,1 L</b> → 07/94	G/D	<b>3293 91</b> → 01/93 (* 95 631 464 80 96 044 510 80 96 135 591 80)	<b>3293 59</b> → 01/93 (* 95 025 088 80)
		<b>3293 96</b> 01/93 → (* 96 151 289 80 96 172 452 80)	<b>3287 79</b> 01/93 → (* 96 098 023 80 96 210 475 80)
(XU10J4R) <b>Ess 2 L 16 S</b> 07/94 → (XUD11A) <b>DI Atmo 2,1 L</b> 07/94 →	G/D	<b>3293 96</b> (* 96 151 289 80 96 172 452 80)	<b>3287 79</b> (* 96 098 023 80 96 210 475 80)

## BV - ME5T BVA - 4HP18

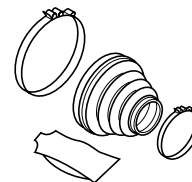

	G/D	Côté Roue	Côté BV
(XU10J2-XU10J2TE) <b>Ess 2 L - 2 L IE Turbo</b> → 07/94 (ZPJ-ZPJ4) <b>V6 3 L</b> → 07/94 (XUD11ATE) <b>DI Turbo 2,1 L</b> → 07/94	G/D	<b>3293 95</b> (* 95 640 328 80 96 145 087 80)	<b>3287 72</b> (* 95 640 335 80)
(XU10J2TE) <b>Ess 2 L IE Turbo</b> 07/94 → (XU10J4R) <b>Ess 2 L 16 S</b> 07/94 → (ZPJ) <b>Ess V6 3L</b> 07/94 → (XUD11ATE-XUD11BTE) <b>DI Turbo 2,1 L</b> 07/94 →	G/D	<b>3293 98</b> <b>RP 3293 A1</b> (* 14 765 260 80)	<b>3287 90</b> (* 96 170 544 80)
		<b>3293 02</b> (* 96 211 576 80)	<b>3287 80</b> (* 96 209 941 80)



# CITROËN XM

## BV - MG5T

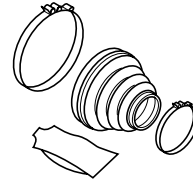

G D	<b>Côté Roue</b>	<b>Côté BV</b>
G/D	<b>3293 02 •• (Ø 20)</b> (* 96 211 576 80)	<b>3287 80 ••</b> (* 96 209 941 80)
	<b>3293 98 • (Ø 20)</b> <b>RP 3293 A1</b> (* 14 765 260 80)	<b>3287 90</b> (* 96 170 544 80)

(ZPJ-ZPJ4)

**Ess 3 L V6**

(DK5ATE)

**DI Turbo 2,5 L**

## BV - ML5T BVA - 4HP20

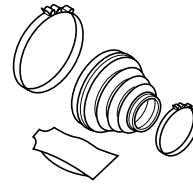



G D	<b>Côté Roue</b>	<b>Côté BV</b>
G/D	<b>3293 02 •• (Ø 20)</b> (* 96 211 576 80)	<b>3287 80 ••</b> (* 96 209 941 80)

(ES9J4)

**Ess 3 L V6**

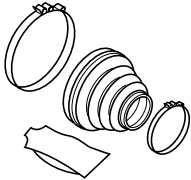
# CITROËN EVASION

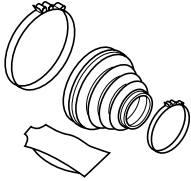
<b>CITROËN EVASION</b>			
<b>BV - BE3/5- BE3R - BE4R BVA - AL4</b>			
	<b>G/D</b>	<b>Côté Roue</b>	<b>Côté BV</b>
(XU7JP-XU10J2-EW10J4) <b>Ess 1,8 L - 2 L - 2 L 16 S</b>	<b>G/D</b>	<b>3293 01</b> → 12/99 (* ZF 82 483 504)	<b>3287 79</b> (* 96 098 023 80 96 210 475 80)
		<b>3293 96</b> 12/99 → 10/2000 (* 96 251 770 80)	
		<b>3293 33</b> 10/2000 → (* 96 286 049 80)	
<b>BV - ME</b>			
(XU10J2TE) <b>Ess 2 L Turbo</b> → 12/96 (XUD9TE) → 04/96 <b>DI Turbo 1,9 L</b>	<b>G/D</b>	<b>Côté Roue</b>	<b>Côté BV</b>
	<b>G/D</b>	<b>3293 00</b> (* 96 170 794 80)	<b>3287 90</b> (* 96 347 664 80 96 170 544 80)
<b>BV - ML5T</b>			
(XU10J2TE) <b>Ess 2 L Turbo</b> 12/96 → (XU10J4R) <b>Ess 2 L 16 S</b> (XUD9TE) 04/96 → <b>DI Turbo 1,9 L</b> (XUD11BTE) <b>DI Turbo 2,1 L</b> 12/96 → (DW10ATED-DW10ATED4) <b>DI Turbo 2 L HDi - 2 L HDi 16 S</b>	<b>G/D</b>	<b>Côté Roue</b>	<b>Côté BV</b>
	<b>G/D</b>	<b>3293 00</b> → 09/96 (* 96 170 749 80)	<b>3287 90</b> (* 96 347 664 80 * 96 170 544 80)
<b>G/D</b>	<b>3293 06</b> 09/96 → (* 96 212 704 80)		

# CITROËN C15

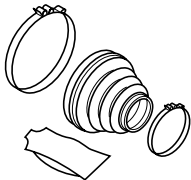
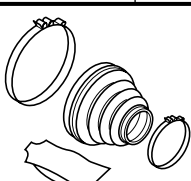
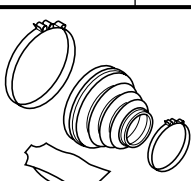
<b>BV - BH3</b>			
		<b>Côté Roue</b>	<b>Côté BV</b>
(XV8-XW7-XY7) Ess 1 L - 1,1 L - 1,4 L → 09/87	(GLAENZER)	<b>3293 74</b>	<b>3287 61</b>
(XV8-XW7-XY7) Ess 1 L - 1,1 L - 1,4 L → 09/87	(CITROËN)	<b>95 532 950</b>	
<b>BV - MA</b>			
		<b>Côté Roue</b>	<b>Côté BV</b>
(TU9-TU1-TU3) Ess 1 L - 1,1 L - 1,4 L 05/88 →		<b>3293 74</b> → 09/91 2 gorges	<b>3287 69</b> → 04/95 Avec gorge d'accrochage
		<b>3293 77</b> 10/91 → 04/95 1 gorge	
		<b>3293 05</b> 04/95 → Sans gorge d'accrochage	<b>3287 83</b> 04/95 → Sans gorge d'accrochage
<b>BV - BE1 - BE3</b>			
		<b>Côté Roue</b>	<b>Côté BV</b>
(E1A-G1A) Ess 1,118 L - 1,294 L		<b>3293 74</b> 2 gorges	<b>3287 70</b>
		<b>3293 83</b> (* 96 009 166 80)	<b>3293 59</b> (* 95 025 088 80)
		<b>3293 77</b> 1 gorge	<b>3287 79</b> (* 96 098 023 80 96 210 475 80)
		<b>3293 05</b> Sans gorge d'accrochage	<b>3287 83</b> Sans gorge d'accrochage

**Avec gorge d'accrochage** : With locating grooves - Con ranura de enganche - Com garganta de engate - Mit aufnehmerillen - Con scanalatura d'aggancio - Met verankeringsgroeven  
**Sans gorge d'accrochage** : Without locating grooves - Sin ranura de enganche - Sem gola garganta de engate - Ohne aufnehmerillen - Senza scanalatura d'aggancio -

\* **Inscription** : Inscription - Inscripción - Inscrição - Aufschrift - Iscrizione - Merketen





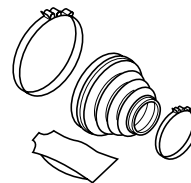

# CITROËN C15

## BV - BE1 - BE3

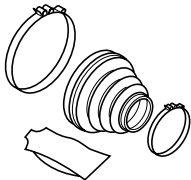

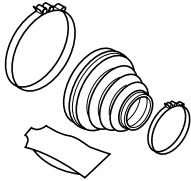
	G/D	Côté Roue	Côté BV
(XUD7) DI 1,8 L	G/D	<b>3293 83</b> → 05/95 (* 96 009 166 80)	<b>3287 69</b> 10/87 → 05/95 (* 32 149 7)
			<b>3293 59</b> → 01/93 (* 95 025 088 80)
		<b>3293 77</b> → 05/95 1 gorge	<b>3287 79</b> 01/93 → 05/95 (* 96 098 023 80)
		<b>3293 74</b> → 05/95 2 gorge	<b>3287 70</b> → 05/95 (* 32 140 99)
(XUD7-DW8B) DI 1,8 L - 1,9 L	G/D	<b>3293 05</b> 05/95 → (* 24 488 61)	<b>3287 83</b> 05/95 → Sans gorge d'accrochage

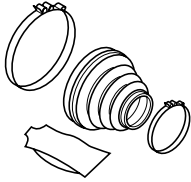
# CITROËN BERLINGO (VP-VU)

<b>BV - MA</b>				
				<b>G</b>
(TU1M-TU3.2-TU3JP) <b>Ess 1,1 L - 1,4 L</b>		<b>G/D</b>	<b>Côté Roue</b>	<b>Côté BV</b>
	→ 07/99		<b>3293 05</b> (* 2 448 861)	<b>3287 69</b> Avec gorge d'accrochage
	07/99 →		<b>3293 20</b>	<b>3287 83</b> Sans gorge d'accrochage
(TU1M-TU3.2-TU3JP) <b>Ess 1,1 L - 1,4 L</b>		<b>G/D</b>	<b>Côté Roue</b>	<b>Côté BV</b>
	→ 11/98		<b>3293 14</b> (* 2 152 022 0595 00)	<b>3287 74</b> (* 95 639 782 80)
	11/98 →		<b>3293 20</b>	<b>3287 88</b>
<b>BV - BE3</b>				
				<b>G</b>
(XU7JB) <b>Ess 1,8 L</b>		<b>G/D</b>	<b>Côté Roue</b>	<b>Côté BV</b>
(XUD7-XUD9) <b>DI 1,8 L - 1,9 L</b>			<b>3293 03</b> (* 96 214 349 80)	<b>3287 81</b> (* 96 209 940 80)
(DW10TD) <b>DI Turbo 2 L HDi</b>				
(XU7JB) <b>Ess 1,8 L</b>		<b>G/D</b>	<b>Côté Roue</b>	<b>Côté BV</b>
				<b>3287 81</b> → 02/2000 (* 96 209 940 80)
				<b>3287 92</b> 02/2000 → (* 96 209 940 80)
<b>BV - SA18</b>				
				<b>G</b>
		<b>G/D</b>	<b>Côté Roue</b>	<b>Côté BV</b>
			<b>3293 05</b> (* 244 886 1)	<b>3287 83</b>

**Avec gorge d'accrochage :** With locating grooves - Con ranura de enganche - Com garganta de engate - Mit aufnehmerillen - Con scanalatura d'aggancio - Met verankeringsgroeven  
**Sans gorge d'accrochage :** Without locating grooves - Sin ranura de enganche - Sem gola garganta de engate - Ohne aufnehmerillen - Senza scanalatura d'aggancio -

\* **Inscription :** Inscription - Inscripción - Inscrição - Aufschrift - Iscrizione - Merketen

 **Electrique :** Elctric - Elctrico - Elctrico - Elektrisch - Elettrico - Electrisch

# CITROËN JUMPY

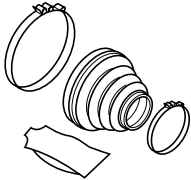
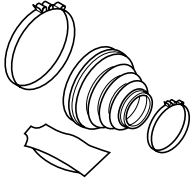
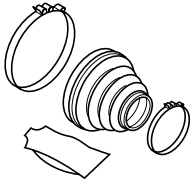
<b>BV - BE3 - BE3R - BE4R</b>			
			
	<b>G/D</b>	<b>Côté Roue</b>	<b>Côté BV</b>
<b>BE3 → 09/98</b>	<b>G/D</b>	<b>3293 01 •</b> (* ZF 82 483 504)	<b>3287 79 •</b> (* 96 098 023 80 96 210 475 80)
(1580SPI-XU7JP) <b>Ess 1,6 L - 1,8 L</b> (XUD9-DW8) <b>DI Atmo 1,9 L</b>		<b>3293 03 ••</b> (* 96 214 349 80)	<b>3287 81 ••</b> (* 96 209 940 80)
<b>BE3R - BE4R 09/98 →</b>	<b>G/D</b>	<b>3293 01 •</b> →12/99 (* ZF 82 483 504)	<b>3287 79 •</b> (* 96 098 023 80) (* 96 210 475 80)
(1580SPI-XU7JP) <b>Ess 1,6 L - 1,8 L</b> (EW10J4) <b>Ess 2 L 16 S</b> (XUD9-DW8) <b>DI Atmo 1,9 L</b>		<b>3293 96 •</b> 12/99 →10/2000 (* 96 251 770 80)	
		<b>3293 33 ••</b> 10/2000 → (* 96 386 049 80)	
		<b>3293 03 ••</b> (* 96 214 249 80)	<b>3287 81 ••</b> (* 96 209 940 80)
			
<b>BV - ME</b>			
	<b>G/D</b>	<b>Côté Roue</b>	<b>Côté BV</b>
(XUD9TE) <b>DI Turbo 1,9 L</b>	<b>G/D</b>	<b>3293 00</b> (* 96 170 794 80)	<b>3287 90</b> (* 96 098 024 80 96 170 544 80 96 347 644 80)
			
<b>BV - ML</b>			
	<b>G/D</b>	<b>Côté Roue</b>	<b>Côté BV</b>
(XUD9TE) <b>DI Turbo 1,9 L</b> (DW10ATED-DW10BTED) <b>DI Turbo 2 L HDi</b> (DW10ATED4) <b>DI Turbo 2 L HDI 16 S</b>	<b>G/D</b>	<b>3293 00</b> → 09/96 (* 96 170 794 80)	<b>3287 90</b> (* 96 098 024 80 96 170 544 80 96 347 644 80)
		<b>3293 06</b> 09/96 → (* 96 212 704 80)	

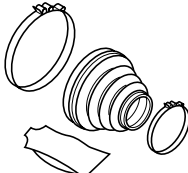
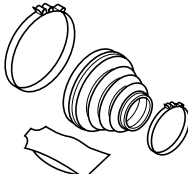

# CITROËN JUMPER 02/2002 →

<b>BV - ML</b>				
		<b>G/D</b>	<b>Côté Roue</b>	<b>Côté BV</b>
(DW10TD) <b>DI Turbo 2L HDi</b>	<b>MLUC</b>	<b>G/D</b>	<b>3293 A1</b> (* 14 882 770 80)	<b>3287 90</b> (* 96 098 024 80 96 170 544 80)
(XU10J2) <b>Ess 2 L</b>	<b>MLGU</b>	<b>G/D</b>	<b>3293 A1</b> (* 14 882 770 80)	<b>3287 90</b> (* 96 098 024 80 96 170 544 80)
(DW12TED) <b>DI Turbo 2,2 L HDi</b> (SOFIM) <b>DI 2,8 L HDi</b>	<b>1000 Kg - 1400 Kg</b>  <b>1800 Kg</b>	<b>G/D</b>	<b>3293 A2</b> (* 14 882 780 80)	<b>3287 78</b> (* 14 002 230 80)
<b>BVA - 4HP20</b>				
		<b>G/D</b>	<b>Côté Roue</b>	<b>Côté BV</b>
(SOFIM) <b>DI 2,8 L HDi</b>	<b>1000 Kg - 1400 Kg</b>  <b>1800 Kg</b>	<b>G/D</b>	<b>3293 A1</b> (* 14 882 770 80)	<b>3287 90</b> (* 96 347 664 80)
		<b>G/D</b>	<b>3293 A2</b> (* 14 882 780 80)	<b>3287 78</b> (* 14 002 230 80)



# CITROËN C25

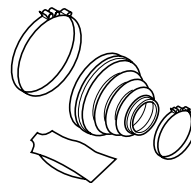

	G / D	Côté Roue	Côté BV
TT Sauf 1,9 L Diesel	G/D	<b>3293 97</b> (* 95 555 103 80 96 047 581 80)	<b>3287 49</b> (* 95 555 106 80)
(XUD9A) DI 1,9 L	G	(* 95 555 103 80 96 047 581 80)	<b>3287 49</b> (* 95 555 106 80)
	D		<b>3287 71</b> (* 95 637 598 80)

# A - LN - LNA - VISA - GS - GSA - CX

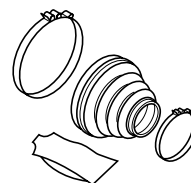
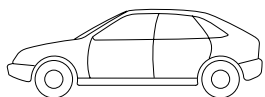



	G D	Côté Roue	Côté BV
<b>A Tous Types</b> (Transmission à billes)	G/D	95 532 941	95 532 947 RP 3293 15
<b>LN 0,602 L - LNA 0,652 L</b>	G/D	3293 83	95 532 947 RP 3293 15
<b>Visa 0,652 L</b>	G/D	95 532 950	95 532 951
<b>LNA 1,124 L</b> <b>Visa 0,954 L - 1,124 L - 1,219 L - 1,360 L</b>	G/D	3293 74	3287 61
<b>Visa GTI - Diesel</b>	G/D	3293 83	3293 59
<b>GS - GSA</b>	G/D	95 543 833	95 532 949
<b>CX 2 L - 2,2 L - 2,4 L Ess</b> <b>CX 2,2 L - 2,5 L Diesel → 07/80</b> <b>CX Reflex - Athena → 07/80</b>	G/D	95 607 723	95 532 953
<b>CX 2,4 L Ess 07/80 → 06/84</b> <b>CX 2,5 L Diesel 07/80 → 06/84</b>			
<b>CX TT BV4 06/84 →</b> <b>CX TT BV5</b> <b>CX Reflex - Athena BV4 07/84 →</b>			3287 49
<b>CX BVA</b>			95 607 723

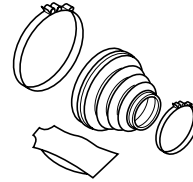

# CITROËN C35

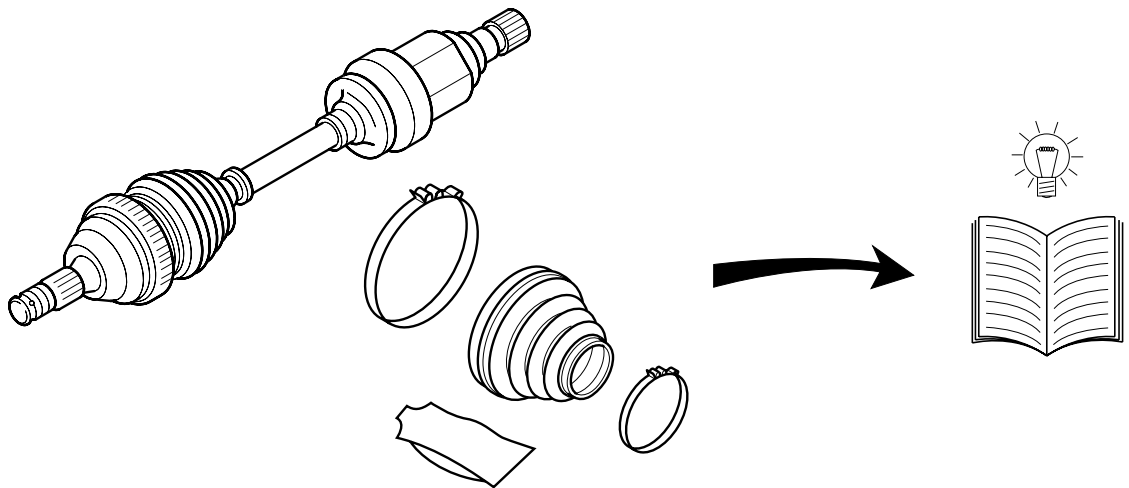





	G / D	Côté Roue	Côté BV
TT	G/D	95 556 710 (* 5 488 095)	95 532 944



N°		N°	
3272 0K	25	3272 6T	26
3272 0L	25	3272 6W	34
3272 0N	14	3272 7G	14
3272 0P	14	3272 7J	6-9
3272 0Q	34	3272 7K	36
3272 0R	29	3272 7L	14-15-16-18-33
3272 0S	29	3272 7N	38
3272 0T	29	3272 7S	12-34
3272 0V	29	3272 7W	34
3272 1F	11-13-15-16-21	3272 85	38
3272 1G	17-19	3272 8C	9
3272 1K	6	3272 8J	6
3272 1L	30-35	3272 8K	36
3272 1N	12-16-17-18-25-34	3272 8L	14-15-16-18-33
3272 1Q	8	3272 8Q	9
3272 1S	20	3272 8R	20
3272 1T	9	3272 8S	12-13-16-18-20-34
3272 2A	25	3272 8V	27
3272 2E	30	3272 9C	30-35
3272 2G	17-19	3272 9G	14-15-16-18-33
3272 2K	9	3272 9J	6
3272 2L	30-35	3272 9K	36
3272 2N	21-22	3272 9L	16-17-34
3272 2Q	8	3272 9P	8
3272 2R	9	3272 9Q	9
3272 2S	20	3272 9R	20
3272 2W	31	3272 9S	8
3272 3J	8	3272 A7	12-13
3272 3K	32	3272 A8	11-21-22
3272 3L	30-35	3272 A9	13
3272 3N	28	3272 AK	37
3272 3Q	8	3272 AN	37
3272 3R	14	3272 C2	36
3272 3W	31	3272 C3	22
3272 4A	25	3272 C5	22
3272 4H	25	3272 CH	36-37
3272 4J	8	3272 CJ	36
3272 4K	32	3272 CK	36-37
3272 4L	35	3272 CL	36
3272 4Q	9	3272 CN	36-37
3272 4S	28	3272 E8	28
3272 4T	26-33	3272 EH	26
3272 4W	25	3272 EJ	26
3272 50	6	3272 EK	26
3272 5A	24	3272 EL	26
3272 5J	8	3272 EN	10
3272 5K	32-39	3272 EQ	10
3272 5L	14-15-16-33	3272 ES	10
3272 5N	28	3272 EV	10
3272 5Q	9	3272 EX	10
3272 5W	14-15-18	3272 FE	18
3272 6A	24	3272 FF	18
3272 6F	14-15-16-18	3272 FG	18-19
3272 6G	25	3272 FH	18
3272 6J	6-9	3272 FJ	20
3272 6K	16-36	3272 FK	19-20
3272 6L	14-15-16-33	3272 G8	23
3272 6Q	9	3272 G9	23

N°		N°	
3272 J0	36	3273 2P	14-15-33
3272 J1	36	3273 2Q	33
3272 J2	36	3273 2W	14
3272 L1	30-35	3272 2X	14
3272 L6	11-14-15	3273 2Y	11-14-15
3272 N0	28	3273 2Z	14
3272 N2	28	3273 3A	14-15
3272 N8	29	3273 3C	14-15
3272 P3	29	3273 3P	9
3272 P4	29	3273 3Q	30-35
3272 P8	28	3273 3Z	11-14-15-16-18-21-33
3272 Q3	23	3273 4L	17
3272 Q4	23	3273 4N	17
3272 Q5	23	3273 4R	25
3272 Q6	23	3273 4T	14-15-16-18
3272 Q7	23-24	3273 4X	25
3272 Q9	23	3273 56	8
3272 R0	23-24	3273 5C	8
3272 R3	32	3273 5E	8
3272 R5	32-39	3273 5F	8
3272 R7	11-14-15	3273 5G	8
3272 R8	11-14-15	3273 5H	6-9
3272 R9	6-9	3273 5J	6
3272 S0	7	3273 5K	6
3272 T1	22	3273 5L	6
3272 T5	24	3273 5N	9
3272 T7	9	3273 5P	32
3272 T9	6-9	3273 5Q	32
3272 V0	30-35	3273 5R	32-39
3272 V2	6-8	3273 5S	36
3272 W5	8	3273 5T	36
3272 W8	8	3273 5V	36
3272 X5	9	3273 5W	36
3272 X6	7	3273 5X	30-35
3272 X7	7	3273 5Y	30-35
3272 Y3	12-16-17-18-20-34	3273 5Z	30-35
3272 Z2	14-15-16-33	3273 63	8
3272 Z7	12-13-16-18-20-34	3273 6A	15-16-33
3273 03	9	3273 6C	14-33
3273 05	6-9	3273 6E	14-15-16-33
3273 06	30-35	3273 6F	14-15-33
3273 08	6-8	3273 6G	14-15-16-18-33
3273 0G	9	3273 6H	14-15-16-18-33
3273 0R	12-13-16-17-18-20-34	3273 6J	12-16-17-34
3273 0V	33	3273 6K	12-13-17-18-20-34
3273 1C	14-15-33	3273 6L	21-22
3273 1L	22-35	3273 6N	28
3273 1N	20	3273 6P	28
3273 1P	25	3273 6R	38
3273 1S	34	3273 6S	38
3273 1T	29	3273 7E	30-35
3273 1V	29	3273 7F	8
3273 1W	29	3273 7G	8
3273 1X	29	3273 7H	8
3273 2F	25	3273 7J	8
3273 2H	25	3273 7K	9
3273 2J	24	3273 7L	9
3273 2K	24	3273 7P	9

N°		N°	
3273 7Q	8	3273 T6	24-28
3273 7R	9	3273 T8	28
3273 7S	16	3273 V4	29
3273 7W	20	3273 V7	30-35
3273 7X	20	3273 V8	29
3273 8A	8	3273 V9	29
3273 8B	9	3273 W3	28
3273 8G	26	3273 W8	23-24
3273 8S	20	3273 W9	23-24
3273 8W	27	3273 X3	23
3273 8Z	31	3273 X8	32
3273 9A	31	3273 Y0	32-39
3273 9G	25-33	3273 Y3	15
3273 9H	25	3273 Y4	6-9
3273 9T	17-19	3273 Y5	7
3273 9V	17-19	3273 Z7	24
3273 9W	25	3273 Z8	24
3273 9X	28	3273 Z9	24
3273 9Y	25	3274 53	39
3273 9Z	34	3274 A8	22
3273 AA	34	3274 A9	39
3273 AP	37	3274 C1	36
3273 AR	37	3274 C2	39
3273 C8	6	3274 C3	39
3273 CH	36-37	3274 C4	32-39
3273 CJ	36	3287 49	66-67
3273 CK	36-37	3287 61	52-60-67
3273 CL	36	3287 69	44-45-47-48-49-52-60-61-62
3273 CN	36-37	3287 70	60-61
3273 EH	26	3287 71	66
3273 EJ	26	3287 72	57
3273 EK	26	3287 74	48-49-52-60-62
3273 EL	26	3287 75	44-45
3273 EN	10	3287 77	60
3273 EQ	10	3287 78	64-65
3273 ES	10	3287 79	47-48-53-54-57-59-60-61-63
3273 EV	10	3287 80	54-56-57-58
3273 EX	10	3287 81	48-49-50-51-54-55-56-62-63
3273 FE	18	3287 83	44-45-47-49-60-61-62
3273 FF	18	3287 85	54
3273 FG	18-19	3287 88	46-49-50-62
3273 FH	18	3287 89	45
3273 FJ	20	3287 90	57-58-60-63-64-65
3273 FK	19-20	3287 91	56
3273 H1	38	3287 92	62
3273 H2	38	3287 93	46
3273 H8	28	3287 94	46
3273 K3	12-13	3287 95	46
3273 K4	11-13-21-22	3293 00	59-63
3273 K7	22	3293 01	59-63
3273 K8	22	3293 02	54-56-57-58
3273 P3	23	3293 03	48-49-50-51-54-55-56-62-63
3273 Q4	28	3293 04	45
3273 Q5	36	3293 05	44-45-47-49-60-61-62
3273 Q7	36	3293 06	59-63
3273 T0	11	3293 08	45
3273 T1	7	3293 11	45
3273 T2	7	3293 12	45

N°		N°	
3293 13	45	95 582 415	39
3293 14	49-62	95 582 416	39
3293 15	67	95 582 438	41
3293 19	45	95 582 439	41
3293 20	46-49-50-62	95 582 440	41
3293 31	50-51	95 606 796	21-22
3293 33	59-63	95 606 797	21-22
3293 34	56	95 606 910	38
3293 35	46	95 606 911	38
3293 51	52-53	95 607 723	67
3293 59	47-48-52-53-57-60-61-67	95 618 339	40
3293 65	52-53	95 618 340	40
3293 74	61-67	95 618 341	40
3293 76	53	95 618 342	40
3293 77	44-47-48-61	95 618 343	40
3293 81	44	95 618 344	40
3293 83	47-48-52-53-54-61-67	95 619 478	21
3293 85	53	95 619 479	21-22
3293 91	47-48-52-53-57	95 619 480	21-22
3293 95	57	95 619 481	39
3293 96	47-48-53-54-57-59-63-64	95 619 482	39
3293 97	66	95 624 470	21-22
3293 98	54-57-58	95 624 471	21-22
3293 99	64	95 624 472	22
3293 A1	54-57-58-64-65	95 624 473	33
3293 A2	64-65	95 624 994	6
3293 A3	46	95 624 995	6
3293 A4	46	95 655 261	21
3273 A5	46	95 655 262	21
3297 00	12-13-14-15-16-17-18-19-20-21-22-23 24-25-26-27-28-29-30-33-39-40	95 661 714	44
3297 02	12-13-14-15-16-17-18-19-20-21 22-23-24-25-26-27-28-29-30-33	95 669 013	11
3297 03	12-13-14-15-16-17-18-19-20-21-22-23 24-25-26-27-28-29-30-31-33-34-35	95 669 014	11
3297 07	33-34	96 060 506	7
3297 12	16-17-30-31-34-35	96 060 507	7
3297 13	16-17-30-31-34-35	96 141 635	23
3297 14	6-7-8-9-14-15-16-32-33-39	96 141 637	23
3318 17	36-38	96 164 213	23
3318 18	36	96 171 856	13
3297 24	6-7-8-9-10-14	96 171 857	13
6922 14	41	96 171 858	11
5 420 543	39	96 171 861	11
5 450 088	40	96 171 874	12
95 532 941	67	96 171 875	12
95 532 944	68	96 173 635	12-22
95 532 947	67	96 173 636	12-22
95 532 949	67	96 173 637	12
95 532 950	67	96 173 638	12
95 532 951	67	96 177 247	11
95 532 953	67	96 177 248	11
95 543 833	67		
95 556 710	68		
95 569 340	38		
95 576 557	38		
95 582 400	39		
95 582 409	39		